

bj·gear



Worm gearboxes

Sturdy and reliable

Customisation is our standard

Customisation is our standard

BJ-Gear A/S is known for reliable transmission solutions and our ability to customise our products to fit your exact needs.

We produce a wide range of standard gearboxes and actuators, and supply e.g. motors, encoders, electromagnetic brakes and couplings of recognised manufacturers, making it possible to supply complete transmission solutions at short notice.

The flexible production machinery together with our modular designed product range allows very short and precise delivery times.

The combination of innovation, know-how, high-technology production facilities and our focus on customer requirements makes us a competent partner.

BJ-Gear is known for reliable transmission solutions for industries such as healthcare, food processing and packaging, aerospace and defense, offshore and marine, the energy and environment sector as well as many other business areas.

End cover ND-side

Angular contact ball bearing

Motor flange

Oil sealing

Worm

Worm wheel

Deep groove ball bearings / tapered roller bearings

Cast iron housing

Oil sealing with dust lip

Side flange / bearing cover

Output shaft

Thread

The BJ-Worm Gear

We are certified according to EN ISO 9001:2015, and our standard worm gear products are supplied for zone 2 and 22 according to the ATEX directive. Products for zone 1 and 21 can be supplied according to the task.

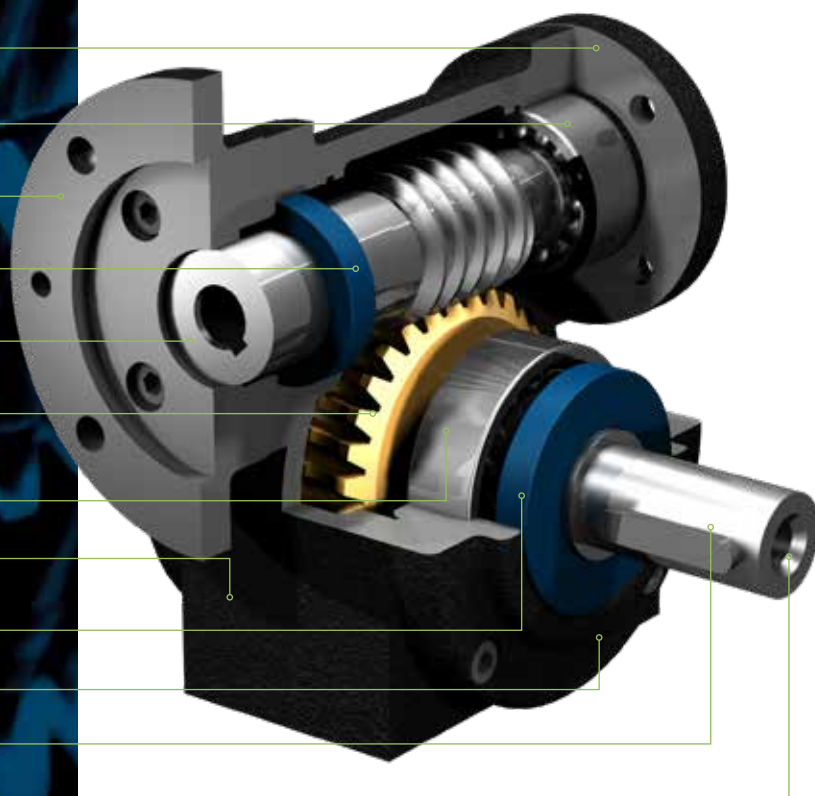

Type designation

1	52	2	0	10	0	13	03	01	30	0	0
---	----	---	---	----	---	----	----	----	----	---	---

We believe that an unambiguous type designation of our worm gearboxes eases the communication. Therefore, throughout this brochure the position of each item in the type designation will be shown. The number 1 indicates that it is a worm gearbox.

Product type

This product catalogue comprises only worm gearboxes of product type 1.

1	52	2	0	10	0	13	03	01	30	0	0
---	----	---	---	----	---	----	----	----	----	---	---

Gear size

We offer gearboxes with centre distances from 42 to 99 mm and with output torques ranging from 10 to 891 Nm.

1	52	2	0	10	0	13	03	01	30	0	0
---	----	---	---	----	---	----	----	----	----	---	---

Housing

We have housing types for different kinds of gear drive assembly. This catalogue comprises our cast iron housings that features high rigidity, low noise, good vibration absorption qualities and tight tolerances.

1	52	2	0	10	0	13	03	01	30	0	0
---	----	---	---	----	---	----	----	----	----	---	---

Output flange

You have the choice of either a bearing cover as the compact solution or a side flange which allows for assembly at the output shaft. Adaptations are possible.

1	52	2	0	10	0	13	03	01	30	0	0
---	----	---	---	----	---	----	----	----	----	---	---

Output shaft

We offer different variants of output shafts. Adaptations are possible.

1	52	2	0	10	0	13	03	01	30	0	0
---	----	---	---	----	---	----	----	----	----	---	---

Output shaft material

Our output shafts are as standard of SS1672-08. Other materials are possible.

1	52	2	0	10	0	13	03	01	30	0	0
---	----	---	---	----	---	----	----	----	----	---	---

D-side (Drive side)

To be mounted at the D-side we offer motor flanges, coupling housings or end covers for other power intake connections. Adaptations are possible.

1	52	2	0	10	0	13	03	01	30	0	0
---	----	---	---	----	---	----	----	----	----	---	---

Input shaft

We offer hollow worm shaft or free worm shaft on the D-side as well as options of through-going worm and free shaft on the ND-side. Adaptations are possible.

1	52	2	0	10	0	13	03	01	30	0	0
---	----	---	---	----	---	----	----	----	----	---	---

ND-side (Non drive side)

It is possible to build on various accessories such as brakes, encoders etc. on the ND-side. Adaptations are possible.

1	52	2	0	10	0	13	03	01	30	0	0
---	----	---	---	----	---	----	----	----	----	---	---

Gear ratio

Indicates the choice of gear ratio. The worm wheel is made of high-quality bronze with a specially fine combination of qualities with regard to low friction, wear and much strength.

1	52	2	0	10	0	13	03	01	30	0	0
---	----	---	---	----	---	----	----	----	----	---	---

Oil / Lubricants

We have a wide range of oil / lubricants for different operating temperatures and for special environments. The gearboxes are as standard life-lubricated with fully synthetic oil.

1	52	2	0	10	0	13	03	01	30	0	0
---	----	---	---	----	---	----	----	----	----	---	---

Finish

We offer surface treatment in different variants. It is also possible to choose your own surface treatment and colour.

1	52	2	0	10	0	13	03	01	30	0	0
---	----	---	---	----	---	----	----	----	----	---	---

Selection guide

1 52 1 0 10 0 13 03 01 30 0 0

Gear size

The BJ-worm gearboxes are available in five standard sizes with housing of cast iron. Other housing materials and sizes are available on request.

The individual sizes are numbered according to the centre distances between the worm and worm wheel. A gearbox with a centre distance of 52.5 mm is designated Series 52 and is assigned number 52 on position no. 2 in the type designation.

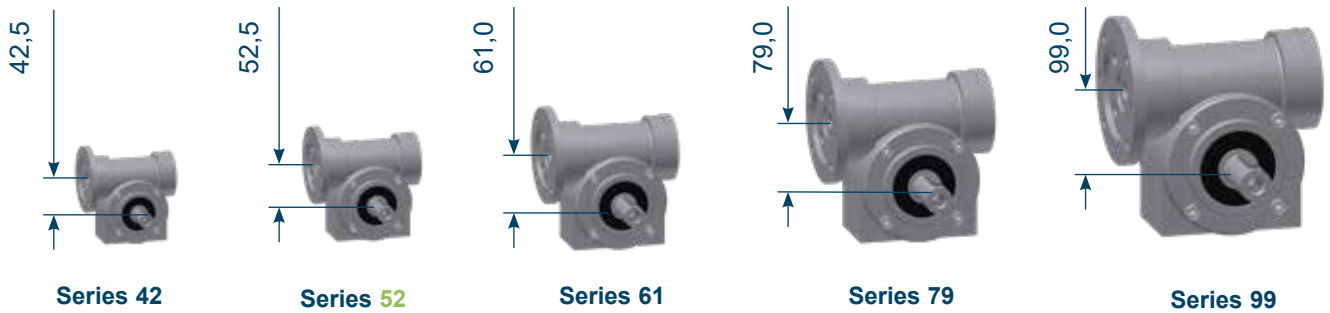

Service factor

The operating conditions are of importance to the durability of the gearbox. The gearbox should therefore be dimensioned by using the service factors mentioned below. Please note that the values apply for operation with an electric standard AC motor.

$$\text{Service factor} = \frac{M_{\text{gear}} \text{ [Nm]}}{M_{\text{required}} \text{ [Nm]}}$$

Type of load	Number of stats per hour	Operation hours per day			
		2	2 - 8	8 - 12	12 - 24
Uniform, smooth load	<50	0,8	0,9	1,0	1,3
	50 - 500	0,9	1,1	1,2	1,5
	500<	1,0	1,2	1,4	1,7
Moderate impact load	<50	0,9	1,1	1,3	1,5
	50 - 500	1,1	1,3	1,5	1,8
	500<	1,3	1,5	1,7	2,0
Heavy impact load	<50	1,3	1,5	1,6	1,8
	50 - 500	1,5	1,7	1,9	2,1
		1,7	2,0	2,1	2,4

Tables of effect

Series 42

Motor			Series 42										
		Gear ratio	5,4:1	7,5:1	10:1	15:1	20:1	25:1	30:1	40:1	50:1	62:1	75:1
[rpm]	[kW]	n ₂ [rpm]	130	93	70	47	35	28	23	18	14	11	9
Output torque [Nm] / Strength factor													
700	0,09		5,3/8,5	7,1/6,7	9,1/6,7	12/7,0	16/3,7	20/9,2	21/6,5	24/3,7	29/2,4	32/1,6	38/1,0
	0,12		7,2/6,4	9,7/5,0	12/5,1	17/5,0	21/2,9	27/7,0	28/5,0	33/2,8	39/1,8	44/1,2	
	0,18 ³⁾		11/4,3	14/3,6	19/3,3	26/3,4	33/1,9	41/4,7	43/3,3	51/1,8			
	0,25 ³⁾		15/3,2	20/2,5	26/2,5	37/2,4	46/1,3	57/3,4					
	0,37 ³⁾		23/2,1	31/1,6	40/1,6	55/1,6							
	0,55 ³⁾		34/1,4	46/1,1									
[rpm]	[kW]	n ₂ [rpm]	167	120	90	60	45	36	30	23	18	15	12
Output torque [Nm] / Strength factor													
900	0,09					9,9/7,7	12/4,6	15/11,4	16/8,1	20/4,4	23/2,9	26/1,9	30/1,2
	0,12		5,6/7,5	7,6/5,9	9,7/5,9	13/6,0	17/3,3	21/8,3	23/5,7	28/3,2	32/2,1	36/1,4	
	0,18		8,6/5,0	11/4,2	15/3,9	21/3,8	26/2,2	32/5,6	35/3,9	43/2,2	50/1,4		
	0,25		12/3,6	16/2,9	21/2,8	29/2,8	37/1,6	46/4,0	49/2,8				
	0,37 ³⁾		18/2,5	24/2,0	31/1,9	44/1,9							
	0,55 ³⁾		27/1,7	37/1,3	47/1,3								
	0,75 ³⁾		37/1,2										
[rpm]	[kW]	n ₂ [rpm]	259	187	140	93	70	56	47	35	28	23	19
Output torque [Nm] / Strength factor													
1400	0,09				4,6/10	6,5/10	8,3/5,6	10/14,2	11/9,9	14/5,5	15/3,6	17/2,5	20/1,6
	0,12		3,5/9,6	4,7/7,7	6,2/7,6	8,8/7,5	11/4,2	14/10,5	15/7,5	18/4,2	21/2,8	24/1,8	28/1,2
	0,18		5,5/6,4	7,4/5,1	9,7/5,0	13/5,3	17/2,9	21/7,2	23/5,1	28/2,8	33/1,8	37/1,2	
	0,25		7,8/4,6	10/3,8	13/3,8	19/3,7	24/2,1	30/5,1	33/3,6	40/2,0			
	0,37		11/3,3	15/2,6	20/2,5	29/2,4	37/1,4	45/3,5	49/2,4				
	0,55 ³⁾		17/2,2	23/1,7	31/1,6	43/1,6							
	0,75 ³⁾		24/1,5	32/1,2	42/1,2								
[rpm]	[kW]	n ₂ [rpm]	519	373	280	187	140	112	93	70	56	45	37
Output torque [Nm] / Strength factor													
2800	0,18		2,6/8,7	3,6/6,9	4,7/6,9	6,8/6,7	8,7/3,8	11/9,3	12/6,8	14/4,0	17/2,6	20/1,7	23/1,1
	0,25		3,8/6,2	5,2/4,9	6,8/4,9	9,7/4,9	12/2,7	15/7,0	17/4,9	21/2,8	25/1,8	29/1,2	
	0,37		5,9/4,1	8,0/3,3	10/3,4	14/3,5	19/1,8	23/4,8	26/3,3	32/1,8			
	0,55		8,9/2,8	12/2,2	15/2,3	22/2,2	29/1,2	35/3,2					
	0,75 ³⁾		12/2,1	16/1,7	21/1,7	31/1,6							
	1,10 ³⁾		18/1,4	24/1,1	32/1,1								
	1,50 ³⁾		25/1,0										

The values apply for gearboxes which are well run in and properly heated for operation, see page 33.

According to IE3 efficiency level, EU Directive 2009/125/EC, Regulation (EC) No. 640/2009. 2) High output design. 3) Assembly through coupling.

Tables of effect

Series 52

Motor			Series 52							
[rpm]	[kW]	Gear ratio n ₂ [rpm]	7,5:1	10:1	15:1	19:1	30:1	38:1	51:1	62:1
			93	70	47	37	23	18	14	11
Output torque [Nm] / Strength factor										
700	0,12		9,5/8,8	12/8,9	17/8,9	21/5,4	29/8,6	34/5,4	40/3,0	45/2,1
	0,18		14/6,2	19/5,8	27/5,7	31/3,8	45/5,7	53/3,6	62/2,0	70/1,4
	0,25		21/4,3	27/4,2	38/4,2	46/2,6	63/4,2	75/2,6	88/1,4	
	0,37		31/2,9	40/2,9	57/2,8	69/1,8	95/2,8	113/1,7	132/1,0	
	0,55		47/1,9	61/1,9	86/1,9	104/1,2				
	0,75 ³⁾		65/1,4	83/1,4	118/1,4					
			120	90	60	47	30	24	18	15
Output torque [Nm] / Strength factor										
900	0,18		11/7,2	14/7,1	21/6,7	25/4,3	35/6,8	42/4,2	50/2,4	57/1,6
	0,25		16/5,1	21/4,9	29/5,0	36/3,1	50/4,9	60/3,0	71/1,7	81/1,1
	0,37		24/3,5	31/3,4	45/3,3	54/2,1	76/3,3	90/2,1	108/1,1	
	0,55		37/2,2	47/2,3	67/2,2	82/1,4	114/2,2			
	0,75		51/1,6	65/1,6	92/1,6	113/1,0				
	1,10		75/1,1	96/1,1						
	1,50 ³⁾		102/0,8							
			187	140	93	74	47	37	27	23
Output torque [Nm] / Strength factor										
1400	0,25		10/6,4	13/6,3	18/6,4	23/3,9	32/6,1	39/3,8	46/2,2	53/1,5
	0,37		15/4,4	20/4,2	28/4,2	35/2,6	49/4,1	59/2,5	71/1,4	80/1,0
	0,55		23/2,9	30/2,8	43/2,8	53/1,8	74/2,8	89/1,8		
	0,75		32/2,1	41/2,1	59/2,1	74/1,3	101/2,0			
	1,10		48/1,4	62/1,4	88/1,4					
	1,50		65/1,1	85/1,0						
			373	280	187	147	93	74	55	45
Output torque [Nm] / Strength factor										
2800	0,37		7,6/5,5	10/5,4	14/5,6	18/3,4	25/5,6	31/3,4	38/1,9	45/1,3
	0,55		11/3,9	15/3,9	22/3,6	27/2,3	39/3,7	47/2,3	58/1,3	68/0,9
	0,75		16/2,8	21/2,7	30/2,7	38/1,7	54/2,7	66/1,7	81/0,9	
	1,10		24/1,9	31/1,9	45/1,8	56/1,2	80/1,8			
	1,50		33/1,4	43/1,4	62/1,3	78/0,8				
	2,20		49/0,9	64/0,9						

The values apply for gearboxes which are well run in and properly heated for operation, see page 33.

According to IE3 efficiency level, EU Directive 2009/125/EC, Regulation (EC) No. 640/2009. 2) High output design. 3) Assembly through coupling.

Tables of effect

Series 61

Motor			Series 61							
		Gear ratio	7:1	10:1	15:1	21:1	30:1	40:1	48:1	60:1
[rpm]	[kW]	n ₂ [rpm]	100	70	47	33	23	18	15	12
Output torque [Nm] / Strength factor										
700	0,18		13/17,5	19/9,0	27/8,9	35/17,3	47/8,8	56/5,0	64/3,3	70/2,2
	0,25		19/12,9	27/6,5	39/6,2	50/12,3	67/6,2	82/3,5	90/2,4	99/1,6
	0,37		29/8,7	41/4,3	58/4,3	75/8,3	101/4,2	123/2,4	136/1,6	149/1,1
	0,55		44/5,8	62/2,9	88/2,8	112/5,6	152/2,8	185/1,6		
	0,75 ³⁾		61/4,2	85/2,1	121/2,1	154/4,1	208/2,1			
	1,10 ³⁾		90/2,9	126/1,4	178/1,4					
	1,50 ³⁾		123/2,1	172/1,1						
[rpm]	[kW]	n ₂ [rpm]	129	90	60	43	30	23	19	15
Output torque [Nm] / Strength factor										
900	0,25		15/14,6	21/7,4	30/7,3	39/14,1	52/7,3	64/4,1	72/2,8	80/1,8
	0,37		23/9,6	32/5,0	45/5,0	58/9,6	79/4,9	97/2,7	109/1,9	120/1,2
	0,55		34/6,7	48/3,4	69/3,3	88/6,4	119/3,3	146/1,8	164/1,3	
	0,75		47/4,8	66/2,4	95/2,4	121/4,7	164/2,4			
	1,10		70/3,3	98/1,7	140/1,6	179/3,2				
	1,50 ²⁾		96/2,4	134/1,2						
	2,20 ³⁾		141/1,6							
[rpm]	[kW]	n ₂ [rpm]	200	140	93	67	47	35	29	23
Output torque [Nm] / Strength factor										
1400	0,25		9,6/17,8	13/9,5	19/9,4	25/17,4	33/9,2	41/5,1	47/3,6	53/2,3
	0,37		14/12,5	20/6,3	29/6,3	38/11,8	51/6,2	62/3,5	72/2,4	80/1,5
	0,55		22/8,1	31/4,2	45/4,1	57/8,0	77/4,1	94/2,3	109/1,6	122/1,0
	0,75		30/6,0	42/3,1	62/3,0	79/5,8	106/3,0	129/1,7	151/1,2	
	1,10		45/4,1	63/2,1	91/2,1	117/4,0	157/2,1			
	1,50		62/3,0	86/1,5	125/1,5					
	2,20 ²⁾		91/2,0	128/1,0						
[rpm]	[kW]	n ₂ [rpm]	400	280	187	133	93	70	58	47
Output torque [Nm] / Strength factor										
2800	0,37		7/15,1	10/8,1	14/8,3	18/15,2	25/8,3	32/4,5	37/3,2	43/2,0
	0,55		11/10,0	15/5,5	22/5,4	28/10,1	39/5,5	49/3,0	57/2,1	65/1,4
	0,75		15/7,5	21/4,0	30/4,0	39/7,4	55/3,9	68/2,2	80/1,5	91/1,0
	1,10		22/5,2	32/2,7	45/2,7	58/5,1	82/2,7	102/1,5	119/1,1	
	1,50		31/3,7	44/2,0	63/2,0	81/3,6	112/2,0			
	2,20		46/2,5	65/1,4	93/1,3	119/2,5				
	3,00 ²⁾		63/1,8	89/1,0						
	4,00 ³⁾		84/1,4							

The values apply for gearboxes which are well run in and properly heated for operation, see page 33.

According to IE3 efficiency level, EU Directive 2009/125/EC, Regulation (EC) No. 640/2009. 2) High output design. 3) Assembly through coupling.

Tables of effect

Series 79

Motor			Series 79							
		Gear ratio	7,33:1	10:1	15:1	21:1	30:1	42:1	50:1	62:1
[rpm]	[kW]	n ₂ [rpm]	95	70	47	33	23	17	14	11
Output torque [Nm] / Strength factor										
700	0,37		31/16,4	43/8,5	59/8,5	79/4,2	104/8,3	136/4,2	153/3,0	171/1,9
	0,55		47/11,0	65/5,7	90/5,6	120/2,8	157/5,6	205/2,8	230/2,0	258/1,3
	0,75		65/8,0	89/4,2	124/4,1	165/2,1	216/4,1	282/2,1	316/1,5	
	1,10		97/5,4	132/2,9	183/2,8	245/1,4				
	1,50		133/4,0	181/2,1	251/2,1					
	2,20 ³⁾		196/2,7							
[rpm]	[kW]	n ₂ [rpm]	123	90	60	43	30	21	18	15
Output torque [Nm] / Strength factor										
900	0,55		36/12,7	48/6,6	69/6,5	94/3,3	123/6,4	166/3,3	183/2,3	214/1,5
	0,75		50/9,3	67/4,8	96/4,7	130/2,4	169/4,7	228/2,4	252/1,7	294/1,1
	1,10		75/6,3	99/3,3	142/3,2	192/1,6	250/3,2	337/1,6		
	1,50		103/4,6	136/2,4	195/2,4	263/1,2				
	2,20		152/3,1	200/1,6	287/1,6					
	3,00 ³⁾		208/2,3							
[rpm]	[kW]	n ₂ [rpm]	191	140	93	67	47	33	28	23
Output torque [Nm] / Strength factor										
1400	0,75		32/11,2	42/6,0	62/5,8	82/3,1	112/5,8	149/3,0	167/2,1	196/1,4
	1,10		47/7,8	63/4,1	92/4,0	122/2,1	166/4,0	221/2,1	248/1,4	291/0,9
	1,50		65/5,7	88/2,9	127/2,9	168/1,5	228/2,9			
	2,20		96/3,8	130/2,0	188/2,0	248/1,0				
	3,00		133/2,8	178/1,5	258/1,5					
	4,00		178/2,1	238/1,1						
[rpm]	[kW]	n ₂ [rpm]	382	280	187	133	93	67	56	45
Output torque [Nm] / Strength factor										
2800	1,10		23/9,6	31/5,2	46/5,0	63/2,7	63/5,0	114/2,7	134/1,9	153/1,2
	1,50		32/7,1	44/3,7	64/3,7	87/2,0	117/3,6	158/2,0	185/1,4	212/0,9
	2,20		48/4,8	64/2,5	95/2,5	129/1,3	173/2,5			
	3,00		66/3,5	90/1,8	131/1,8	177/1,0				
	4,00		88/2,6	120/1,4	175/1,4					
	5,50 ³⁾		122/1,9	167/1,0						

The values apply for gearboxes which are well run in and properly heated for operation, see page 33.

According to IE3 efficiency level, EU Directive 2009/125/EC, Regulation (EC) No. 640/2009. 2) High output design. 3)

Assembly through coupling.

Tables of effect

Series 99

Motor			Series 99							
		Gear ratio	7:1	10:1	15:1	20:1	30:1	40:1	50:1	60:1
[rpm]	[kW]	n2 [rpm]	100	70	47	35	23	18	14	12
Output torque [Nm] / Strength factor										
700	0,75		61/8,8	86/7,5	124/3,7	159/4,1	218/7,3	271/4,1	319/2,6	359/1,8
	1,10		91/5,9	128/5,0	183/5,0	236/2,8	323/5,0	401/2,8	472/1,8	531/1,2
	1,50		125/4,4	175/3,7	251/3,7	323/2,1	442/3,6	549/2,0	647/1,3	724/0,9
	2,20		185/3,0	258/2,5	370/2,5	474/1,4	652/2,5			
	3,00		253/2,2	353/1,9	506/1,8	647/1,0	891/1,8			
	4,00 ³⁾		338/1,6	472/1,4						
	5,50 ³⁾		465/1,2	650/1,0						
[rpm]	[kW]	n2 [rpm]	129	90	60	45	30	23	18	15
Output torque [Nm] / Strength factor										
900	0,75		47/10,0	66/8,4	97/8,3	124/4,7	171/8,3	213/4,7	250/3,0	282/2,1
	1,10		70/6,8	98/5,7	143/5,7	185/3,2	253/5,6	315/3,2	371/2,1	418/1,4
	1,50		97/4,9	134/4,2	197/4,2	253/2,4	348/4,1	432/2,3	509/1,5	574/1,0
	2,20		143/3,4	198/2,9	290/2,8	374/1,6	513/2,8	637/1,6		
	3,00		196/2,4	271/2,1	398/2,1	511/1,2	697/2,1	866/1,2		
	4,00		262/1,8	362/1,6	531/1,5					
	5,50		361/1,3	500/1,2						
7,50 ³⁾		494/1,0								
[rpm]	[kW]	n2 [rpm]	200	140	93	70	47	35	28	23
Output torque [Nm] / Strength factor										
1400	1,10		45/8,0	63/6,9	92/6,8	119/3,8	165/6,8	212/3,9	247/2,5	284/1,7
	1,50		62/5,8	87/5,0	127/5,0	164/2,8	228/4,9	292/2,8	340/1,8	390/1,3
	2,20		91/4,0	126/3,5	188/3,4	242/1,9	337/3,4	431/1,9	502/1,2	
	3,00		125/2,9	177/2,5	257/2,5	331/1,4	461/2,5	591/1,4		
	4,00		168/2,2	238/1,9	345/1,9	443/1,1				
	5,50		232/1,6	328/1,4	475/1,3					
	7,50		317/1,2	448/1,0						
[rpm]	[kW]	n2 [rpm]	400	280	187	140	93	70	56	47
Output torque [Nm] / Strength factor										
2800	1,50		30/7,1	42/6,2	63/6,0	81/3,5	112/6,0	149/3,5	174/2,2	201/1,6
	2,20		45/4,8	63/4,2	93/4,1	121/2,4	166/4,1	222/2,4	259/1,5	298/1,1
	3,00		62/3,5	87/3,0	127/3,0	166/1,7	228/3,0	305/1,7	356/1,1	
	4,00		83/2,6	116/2,3	171/2,3	223/1,3	306/2,3	409/1,3		
	5,50		115/1,9	161/1,7	236/1,7	308/0,9	423/1,6			
	7,50		158/1,4	220/1,2	323/1,2					
	11,00 ³⁾		232/1,0							

The values apply for gearboxes which are well run in and properly heated for operation, see page 33.

According to IE3 efficiency level, EU Directive 2009/125/EC, Regulation (EC) No. 640/2009. 2) High output design. 3) Assembly through coupling.

Strength factor

The strength factor is an expression of the durability of the gearing in relation to breakage. The breakage limit is three times the strength factor.

By normal use, include the service factor on page 11 and choose a strength factor > 1.



In case of special demands on safety or other special conditions, please contact our specialists for further information.

Mounting of the gearbox

1 52 1 0 10 0 13 03 01 30 0 0

There are worm opportunities for types of housing depending on gearbox assembly. "2" indicates that the housing is with support and worm at top.

Second digit in the item number is defined by the choice between a bearing cover or a side flange.

	Housing type 1. Mounting in gear housing	Housing type 2. Housing with support, worm at top	Housing type 3. Housing with support, worm at bottom
Housing type			
Designation number	1	2	3

With bearing cover	With side flange
	
0	1

As standard we offer two options: Bearing cover (0) or a side flange (1). Other options are available on request.

Output shaft

1 52 1 0 10 0 13 03 01 30 0 0

BJ-Gear A/S offers different choices of output shafts. The output shaft may be manufactured in customised diameters and lengths, as well as provided with tothing or spline. Choice of material according to specifications.

	Free shaft, right	Free shaft, left	Double free, shaft	Hollow shaft, mounting holes right	Hollow shaft, mounting holes left
Output shaft types					
Designation number indicating shaft type and size	10	20	30	Ø18 [mm] = 47 Ø20 [mm] = 41 Ø24 [mm] = 42 Ø25 [mm] = 43 Ø30 [mm] = 44 Ø35 [mm] = 45 Ø38 [mm] = 65 Ø40 [mm] = 48 Ø45 [mm] = 49 Ø48 [mm] = 46	Ø18 [mm] = 57 Ø20 [mm] = 51 Ø24 [mm] = 52 Ø25 [mm] = 53 Ø30 [mm] = 54 Ø35 [mm] = 55 Ø38 [mm] = 75 Ø40 [mm] = 58 Ø45 [mm] = 59 Ø48 [mm] = 56

	Series 42	Series 52	Series 61	Series 79	Series 99
Hollow shaft sizes available	Ø18 [mm] *Ø20 [mm]	Ø18 [mm] Ø20 [mm] *Ø24 [mm] Ø25 [mm]	Ø25 [mm] *Ø30 [mm] Ø35 [mm] Ø38 [mm]	Ø30 [mm] *Ø35 [mm] Ø38 [mm] Ø40 [mm]	Ø35 [mm] Ø38 [mm] Ø40 [mm] Ø45 [mm] *Ø48 [mm]

* Standard. Other shaft sizes are available on request, please contact our specialists.

Output shaft material

1 52 1 0 10 0 13 03 01 30 0 0

0	Steel, deep groove ball bearings	Standard for series 42, 52, 61 and 79
1	Stainless steel, deep groove ball bearings	Available
2	Steel, tapered roller bearings	Standard for series 99
3	Stainless steel, tapered roller bearings	Available

D-side

1 52 1 0 10 0 13 03 01 30 0 0

IEC norm (B14)	Motor flange [BCD]	42	52	61	79	99
No flange		00	00	00	00	00
56	65	10	-	-	-	-
63	75	11	11	11	-	-
71	85	12	12	12	-	-
80	100	13	13	13	13	-
90	115	14	14	14	14	14
100/112	130	15	15	15	15	15
132	165	-	16	16	16	16
160	215	-	-	-	17	17



Input shaft

1 52 1 0 10 0 13 03 01 30 0 0

	42	52	61	79	99
Ø9	00	-	-	-	-
Ø11	01	01	-	-	-
Ø14	02	02	02	-	-
Ø19	-	03	03	03	-
Ø24	-	04	04	04	04
Ø28	-	-	-	05	05
Ø38	-	-	-	-	06
Ø9 Free shaft on ND side	20	-	-	-	-
Ø11 Free shaft on ND side	21	21	-	-	-
Ø14 Free shaft on ND side	22	22	22	-	-
Ø19 Free shaft on ND side	-	23	23	23	-
Ø24 Free shaft on ND side	-	24	24	24	24
Ø28 Free shaft on ND side	-	-	-	25	25
Ø38 Free shaft on ND side	-	-	-	-	26



// Motor size and power





Standard motors	Size 63	Size 71	Size 80	Size 90	Size 100/112	Size 132
Motor power [kW] for 700 min ⁻¹	-	0,09	0,18	0,37	0,75	2,2
	-	0,12	0,25	0,55	1,1	3,0
	-	-	-	-	1,5	-
Motor power [kW] for 900 min ⁻¹	0,09	0,18	0,37	0,75	1,5	3,0
	0,12	0,25	0,55	1,1	2,2	4,0
	-	-	-	-	-	5,5
Motor power [kW] for 1400 min ⁻¹	0,12	0,25	0,55	1,1	2,2	5,5
	0,18	0,37	0,75	1,5	3,0	7,5
	-	-	-	-	4,0	-
Motor power [kW] for 2800 min ⁻¹	0,18	0,37	0,75	1,5	3,0	5,5
	0,25	0,55	1,1	2,2	4,0	7,5
	-	-	-	-	-	-

// D-side and input shaft for gearboxes without motor

	Closed ND-side	Throughgoing worm with free shaft on ND-side
Free worm shaft on D-side		
Item number	1-52-20100-3040-01-30-00	1-52-20100-3050-01-30-01

ND-side

1	52	1	0	10	0	13	03	01	30	0	0
---	----	---	---	----	---	----	----	----	----	---	---

Closed end cover.	Torque pin	Open end cover.	Open for brake
			
01	02	30	3(X)*

Closed end cover is to be mounted with a worm without free shaft on ND-side. See page 19 for an example.

Open end cover is to be mounted with a worm with free shaft on ND-side. See page 31 for an example.

* (X) indicates multiple brake flanges.

If another type of ND-side is needed please contact our Sales Department.

Gear ratios

1 52 1 0 10 0 13 03 01 30 0 0

Ratio code	42	52	61	79	99
	Gear ratio n_2 [rpm]	Gear ratio n_2 [rpm]	Gear ratio n_2 [rpm]	Gear ratio n_2 [rpm]	Gear ratio n_2 [rpm]
05	5,4:1	-	-	-	-
07	7,5:1	7,5:1	7:1	7,33:1	7:1
10	10:1	10:1	10:1	10:1	10:1
15	15:1	15:1	15:1	15:1	15:1
20	20:1	19:1	21:1	21:1	20:1
25	25:1	-	-	-	-
30	30:1	30:1	30:1	30:1	30:1
40	40:1	38:1	40:1	42:1	40:1
50	50:1	51:1	48:1	50:1	50:1
60	62:1	62:1	60:1	62:1	60:1
75	75:1	-	-	-	-

Oil and lubricants

1 52 1 0 10 0 13 03 01 30 0 0

	Description	Application	Viscosity	Lubricant
0	Fully synthetic gear oil, standard	Normal load and ambient temp. -25°C to +40°C	220	Klübersynth GH 6 - 220
1	Fully synthetic gear oil	Heavy load and ambient temp. -20°C to >+40°C	460	Klübersynth GH 6 - 460
2	Fully synthetic gear oil	Heavy load and ambient temp. -20°C to >+40°C	680	Klübersynth GH 6 - 680
3	Liquid grease	Normal load and ambient temp. -40°C to >+40°C	1200	Klübersynth GE 46 - 1200
4	Special lubricating oil for food and pharmaceutical industries	Normal load and ambient temp. -20°C to +40°C	460	Klübersynth UH1 6 - 460

Ambient temperatures are guide values depending on the lubricant's composition, the intended use and the application method. All data is based on synthetic oil. Do not mix synthetic oil with mineral oil.

Oil and lubricants quantities

Series 42	Series 52	Series 61	Series 79	Series 99
0,06 litres	0,18 litres	0,21 litres	0,5 litres	1,1 litres

Finish

1	52	1	0	10	0	13	03	01	30	0	0
---	----	---	---	----	---	----	----	----	----	---	---

0	Painted mat-black, standard	RAL 9005
1	No treatment	
2	Primed	
3	Corrosion resistant surface treatment	Chromated
9	Customer specified	

Backlash

Due to an increasing demand for gearboxes to be able to handle more accurate movements, we have developed precision gearboxes. The technology is based on the high qualities generally characterised by worm gearboxes. Besides the special design, production and assembly methods, the gearboxes meet strict precision requirements. On request, we can prove backlash, tolerances etc. by measuring reports.



Gear size	Backlash	
	Standard Gears	Precision Gears
Series 42	< 0,80°	< 0,20°
Series 52	< 0,75°	< 0,20°
Series 61	< 0,70°	< 0,20°
Series 79	< 0,55°	< 0,15°
Series 99	< 0,55°	< 0,15°

The backlash values include all the clearances of bearings and tothing as well as tolerances of keys and key ways, bearing seats etc. The backlash values do not include elastic and static deformations as a result of the loads to which the gearbox is exposed. For further information please contact our specialists.

Bearings at output shaft

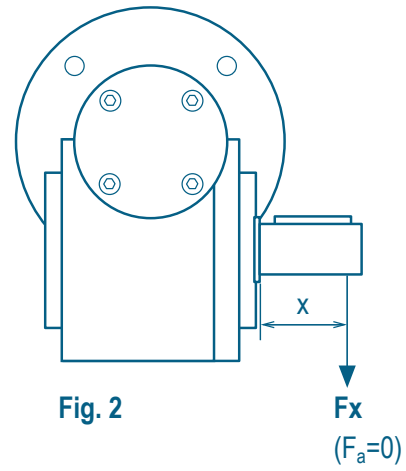
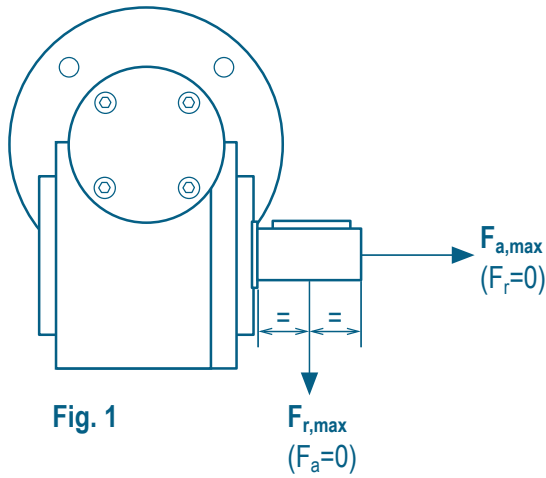

Gear	Force [N]	Ball bearings	Tapered roller bearings	Side flange, free output shaft	
				Ball bearings	Tapered roller bearings
Series 42	$F_{r,max}$	3,100	6,200	3,800	8,300
	$F_{a,max}$	5,300	8,200	5,300	8,200
Series 52	$F_{r,max}$	4,100	7,500	5,100	10,400
	$F_{a,max}$	7,400	11,400	7,400	11,400
Series 61	$F_{r,max}$	6,500	11,300	8,100	15,700
	$F_{a,max}$	11,600	17,400	11,600	17,400
Series 79	$F_{r,max}$	7,600	14,000	9,300	19,500
	$F_{a,max}$	13,200	24,800	13,200	24,800
Series 99	$F_{r,max}$		25,800		27,100
	$F_{a,max}$				25,800

Relocation factor $F_{x,max} = \frac{F_r * a}{X + b}$

Gear	Series 42	Series 52	Series 61	Series 79	Series 99
a [mm]	85,5	98	106	119,5	156
b [mm]	65,5	73	76	87	111

Unique gearbox number

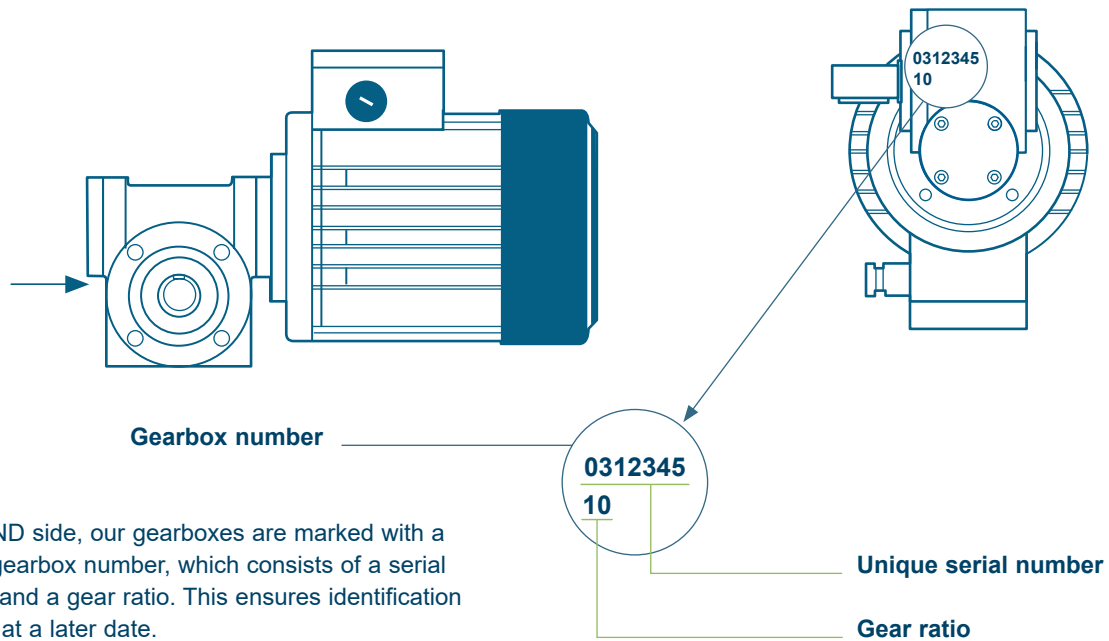

On the ND side, our gearboxes are marked with a unique gearbox number, which consists of a serial number and a gear ratio. This ensures identification anytime at a later date.

By stating the gearbox number, we can always supply a replacement gear.

Position of terminal box

When ordering gear motors please be aware that the terminal box can be placed in different positions. Please inform us if you need the terminal box to be placed in a position of 0°, 90°, 180° or 270°.



Housing type 1

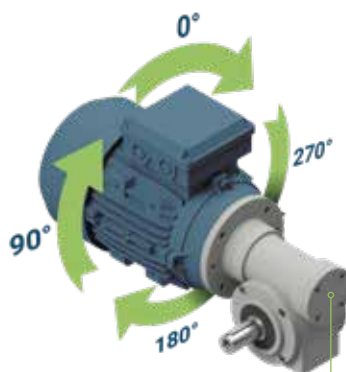

Housing type 2

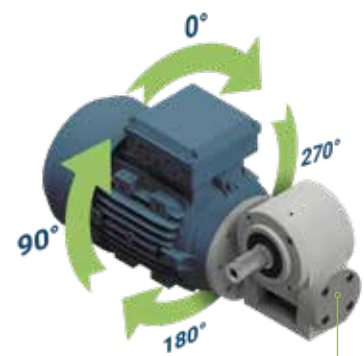

Housing type 3



Dimensional drawings

1 XX 1010X 1X0X 01

Gear house: Housing type 1.

Gear housing with free shaft, right / left, closed end cover.



Free shaft right



Free shaft left

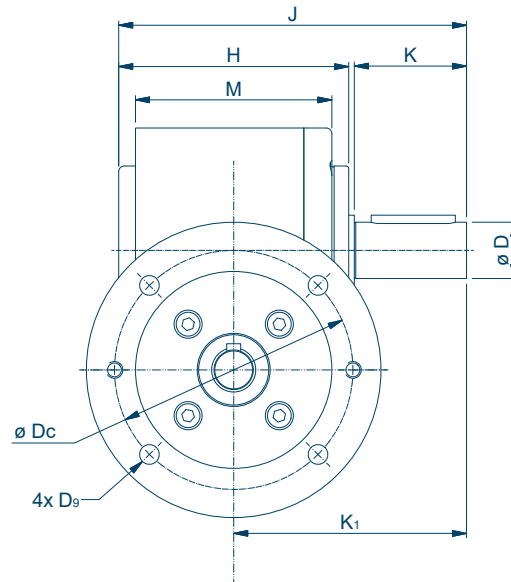
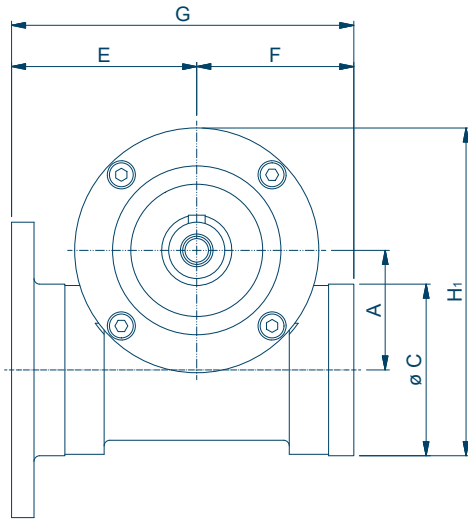
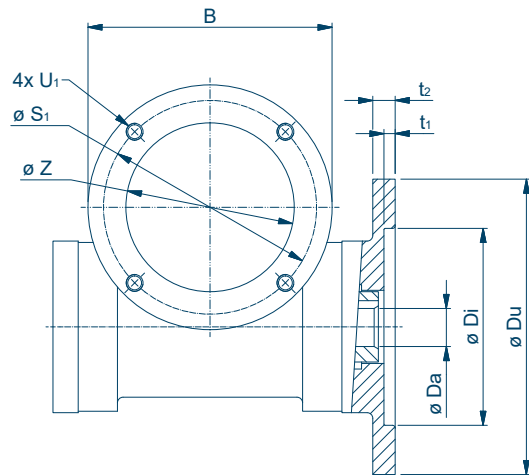

Gear - Free shaft right / left	A	B	C	D*k6	F	H	H ₁	J	K*	K ₁	M	S ₁	Z h6	U ₁	Motor size	Flange size	D ₂ *G7	D _c	D ₁ F6	D _u	D ₃	E	G	t ₁	t ₂	Kg
1 42 10100 1101 01															63	75	11	75	60	90	7	66	122	4	8	4,5
1 42 10100 1202 01	42,5	87	61	20	56	82	116,5	124	40	83	70	76	60	M6	71	85	14	85	70	105	7	66	122	4	8	4,5
1 42 10100 1302 01															80	100	14**	100	80	120	7	66	122	4	8	4,5
1 52 10100 1202 01															71	85	14	85	70	105	7	82	150	4	11	8
1 52 10100 1303 01															80	100	19	100	80	120	7	82	150	4	11	8
1 52 10100 1404 01	52,5	110	72	24	68	92	143,5	144	50	98	80	95	65	M6	90	115	24	115	95	140	9	92	160	4	11	8
1 52 10100 1504 01															100	130	24**	130	110	160	9	82	160	4	11	8
1 61 10100 1202 01															71	85	14	85	70	105	7	91	173	4	11	10
1 61 10100 1303 01															80	100	19	100	80	120	7	91	173	4	11	10
1 61 10100 1404 01	61	126	72	32	82	94	160	156	60	109	83	108	90	M8	90	115	24	115	95	140	9	101	183	4	11	10
1 61 10100 1504 01															100/112	130	24**	130	110	160	9	91	173	4	11	10
1 79 10100 1303 01															80	100	19	100	80	120	7	118	215	4	11	18
1 79 10100 1404 01	79	164	82	38	97	106	202	173	65	120	92	125	105	M10	90	115	24	115	95	140	9	118	215	4	11	18
1 79 10100 1505 01															100/112	130	28	130	110	160	9	126	225	4	11	18
1 99 10100 1404 01															90	115	24	115	95	140	9	150	277	4	9	40
1 99 10100 1505 01	99	208	115	48	126,8	142	260,5	234	90	163	120	165	120	M12	100/112	130	28	130	110	160	9	150	277	4	12	40

Key and keyway according to DIN 6885 | *Special dimensions optional. | ** Not IEC-standard.

Dimensional drawings

1 XX 1030X 1X0X 01

Gear housing type 1.

Gear housing with double free shaft, closed end cover.



Double free shaft

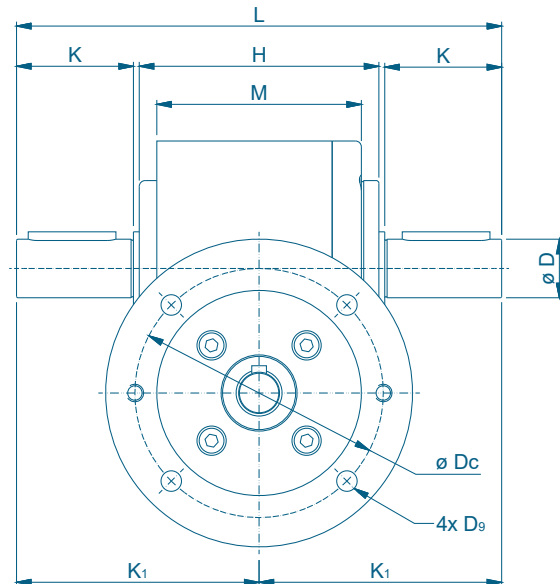
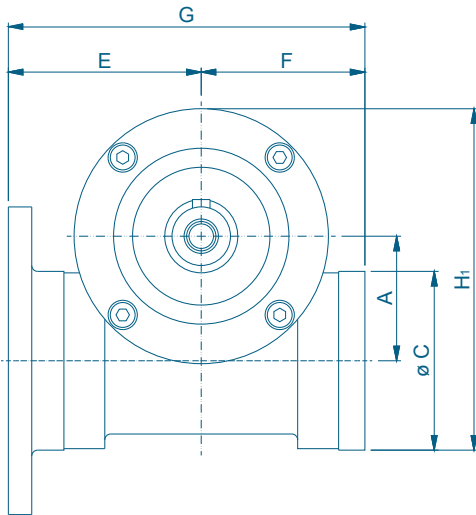
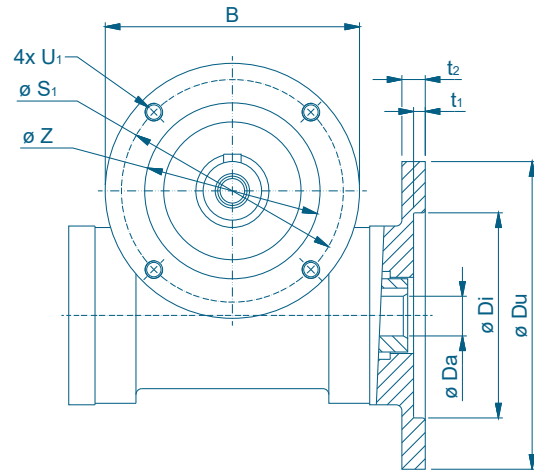

Gearbox - Double free shaft	A	B	C	D *k _s	F	H	H ₁	K*	K ₁	L	M	S ₁	Z h _s	U1	Motor size	Flange size	Da *G ₇	Dc	Di F _s	Du	D _s	E	G	t ₁	t ₂	Kg
1 42 10300 1101 01															63	75	11	75	60	90	7	66	122	4	8	4,5
1 42 10300 1202 01	42,5	87	61	20	56	82	116,5	40	83	166	70	76	60	M6	71	85	14	85	70	105	7	66	122	4	8	4,5
1 42 10300 1302 01															80	100	141)	100	80	120	7	66	122	4	8	4,5
1 52 10300 1202 01															71	85	14	85	70	105	7	82	150	4	11	8
1 52 10300 1303 01															80	100	19	100	80	120	7	82	150	4	11	8
1 52 10300 1404 01	52,5	110	72	24	68	92	143,5	50	98	196	80	95	65	M6	90	115	24	115	95	140	9	92	160	4	11	8
1 52 10300 1504 01															100	130	241)	130	110	160	9	82	160	4	11	8
1 61 10300 1202 01															71	85	14	85	70	105	7	91	173	4	11	10
1 61 10300 1303 01															80	100	19	100	80	120	7	91	173	4	11	10
1 61 10300 1404 01	61	126	72	32	82	94	160	60	109	218	83	108	90	M8	90	115	24	115	95	140	9	101	183	4	11	10
1 61 10300 1504 01															100/112	130	241)	130	110	160	9	91	173	4	11	10
1 79 10300 1303 01															80	100	19	100	80	120	7	118	215	4	11	18
1 79 10300 1404 01	79	164	82	38	97	106	202	65	120	240	92	125	105	M10	90	115	24	115	95	140	9	118	215	4	11	18
1 79 10300 1505 01															100/112	130	28	130	110	160	9	126	225	4	11	18
1 99 10300 1404 01															90	115	24	115	95	140	9	150	277	4	9	40
1 99 10300 1505 01	99	208	115	48	126,8	142	260,5	90	163	326	120	165	120	M12	100/112	130	28	130	110	160	9	150	277	4	12	40

Key and keyway according to DIN 6885 | *Special dimensions optional. | ¹⁾ Not IEC-standard.

Dimensional drawings

1 XX 104XX 1X0X 02

Gear housing type 1.
Gear housing with hollow shaft, mounting holes
right / left, torque pin.



Hollow shaft and mounting threads right

Hollow shaft and mounting threads left

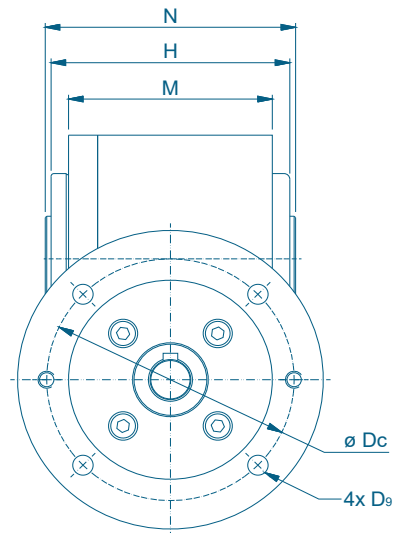
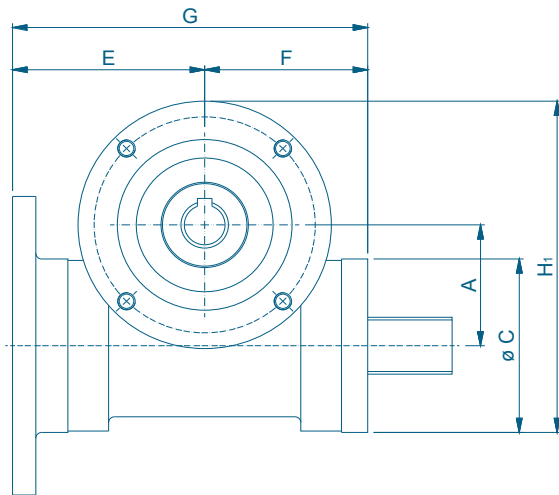
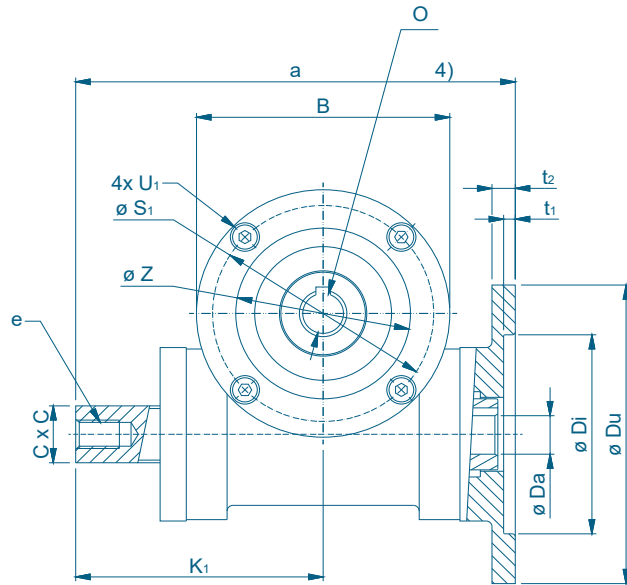

Gearbox - Mounting holes right / left	A	B	C	F	H	H ₁	K ₁	M	N	O*H8	S ₁	Z h6	U ₁	a	cx	c	Motor size	Flange size	D _e *G7	D _c	D ₁ F6	D _u	D ₉	E	G	t ₁	t ₂	Kg
1 42 10410 1101 02																	63	75	11	75	60	90	7	66	122	4	8	4,5
1 42 10410 1202 02	42,5	87	61	56	82	116,5	85	70	86	20	76	60	M6	151	20x20	M10	71	85	14	85	70	105	7	66	122	4	8	4,5
1 42 10410 1302 02																	80	100	141)	100	80	120	7	66	122	4	8	4,5
1 52 10420 1202 02							103										71	85	14	85	70	105	7	82	150	4	11	8
1 52 10420 1303 02							103										80	100	19	100	80	120	7	82	150	4	11	8
1 52 10420 1404 02	52,5	110	72	68	92	143,5	93	80	96	24	95	65	M6	185	25x25	M12	90	115	24	115	95	140	9	92	160	4	11	8
1 52 10420 1504 02							103										100	130	241)	130	110	160	9	82	160	4	11	8
1 61 10440 1202 02							116										71	85	14	85	70	105	7	91	173	4	11	10
1 61 10440 1303 02							116										80	100	19	100	80	120	7	91	173	4	11	10
1 61 10440 1404 02	61	126	72	82	94	160	106	83	98	30	108	90	M8	207	25x25	M12	90	115	24	115	95	140	9	101	183	4	11	10
1 61 10440 1504 02							116										100/112	130	241)	130	110	160	9	91	173	4	11	10
1 79 10450 1303 02							143										80	100	19	100	80	120	7	118	215	4	11	18
1 79 10450 1404 02	79	164	82	97	106	202	143	92	110	35	125	105	M10	261	32x32	M12	90	115	24	115	95	140	9	118	215	4	11	18
1 79 10450 1505 02							135										100/112	130	28	130	110	160	9	126	225	4	11	18
1 99 10460 1404 02																	90	115	24	115	95	140	9	150	277	4	9	40
1 99 10460 1505 02	99	208	115	126,8	142	260,5	185	120	146	48	165	120	M12	335	45x45	M16	100/112	130	28	130	110	160	9	150	277	4	12	40

Key and keyway according to DIN 6885 | *Special dimensions optional. See also page 11 for hollow shaft sizes. | *) Not IEC-standard.

Dimensional drawings

1 XX 1110X 1X0X 01

Gear housing type 1.

Mounting at side flange with free shaft, right / left, closed end cover.

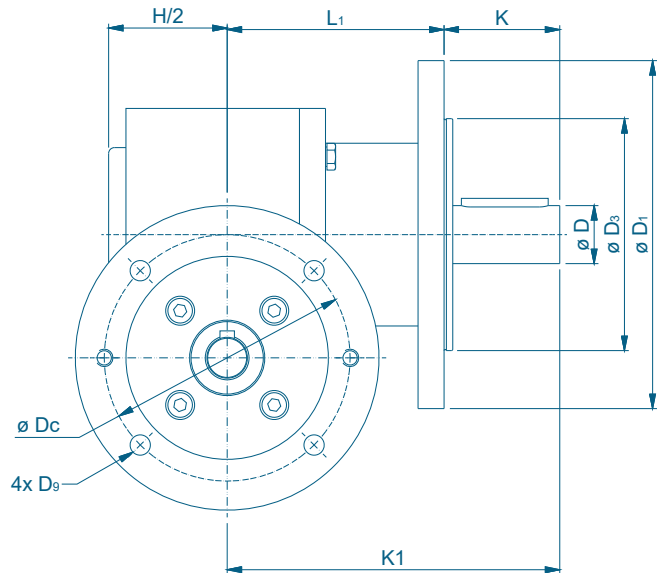
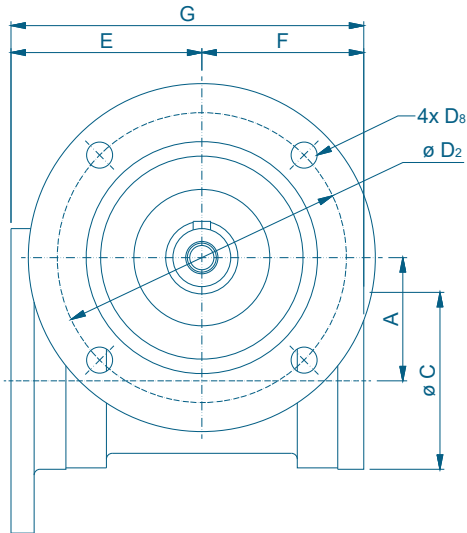
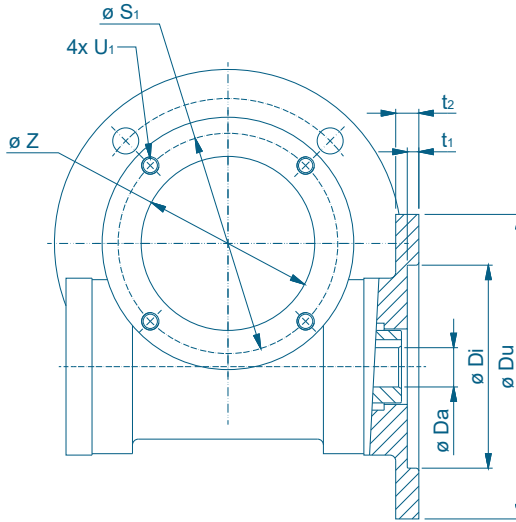
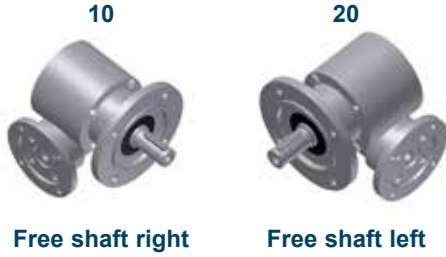

Gearbox - Free shaft right / left	A	C	D*k _e	D1	D ₂	D _{3h_e}	F	D _s	H/2	K*	K ₁	L ₁	S ₁	Z h _e	U ₁	Motor size	Flange size	Da*G _r	Dc	Di F _s	Du	D _s	E	G	t ₁	t ₂	Kg
1 42 11100 1101 01																63	75	11	75	60	90	7	66	122	4	8	5,9
1 42 11100 1202 01	42,5	61	20	120	100	80	56	9	41	40	115	75	76	60	M6	71	85	14	85	70	105	7	66	122	4	8	5,9
1 42 11100 1302 01																80	100	141)	100	80	120	7	66	122	4	8	5,9
1 52 11100 1202 01																71	85	14	85	70	105	7	82	150	4	11	9
1 52 11100 1303 01																80	100	19	100	80	120	7	82	150	4	11	9
1 52 11100 1404 01	52,5	72	24	140	115	95	68	9	46	50	130	80	95	65	M6	90	115	24	115	95	140	9	92	160	4	11	9
1 52 11100 1504 01																100	130	241)	130	110	160	9	82	160	4	11	9
1 61 11100 1202 01																71	85	14	85	70	105	7	91	173	4	11	12
1 61 11100 1303 01																80	100	19	100	80	120	7	91	173	4	11	12
1 61 11100 1404 01	61	72	32	160	130	110	82	9	47	60	145	85	108	90	M8	90	115	24	115	95	140	9	101	183	4	11	12
1 61 11100 1504 01																100/112	130	241)	130	110	160	9	91	173	4	11	12
1 79 11100 1303 01																80	100	19	100	80	120	7	118	215	4	11	23
1 79 11100 1404 01	79	82	38	200	165	130	97	11	53	65	165	100	125	105	M10	90	115	24	115	95	140	9	118	215	4	11	23
1 79 11100 1505 01																100/112	130	28	130	110	160	9	126	225	4	11	23
1 99 11100 1404 01																90	115	24	115	95	140	9	150	277	4	9	47
1 99 11100 1505 01	99	115	48	250	215	180	126,8	15	71	90	205	115	165	120	M12	100/112	130	28	130	110	160	9	150	277	4	12	47

Key and keyway according to DIN 6885 | *Special dimensions optional. | ¹⁾ Not IEC-standard.

Dimensional drawings

1 XX 114XX 1X0X 01

Gear housing type 1. Mounting at side flange with hollow shaft, mounting holes right / left, closed end cover.

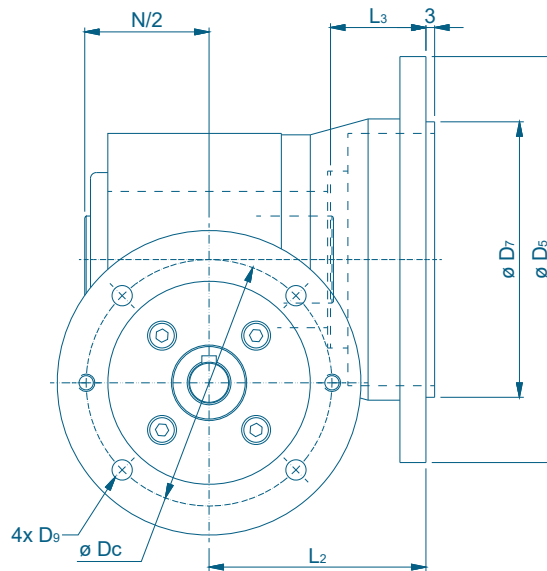
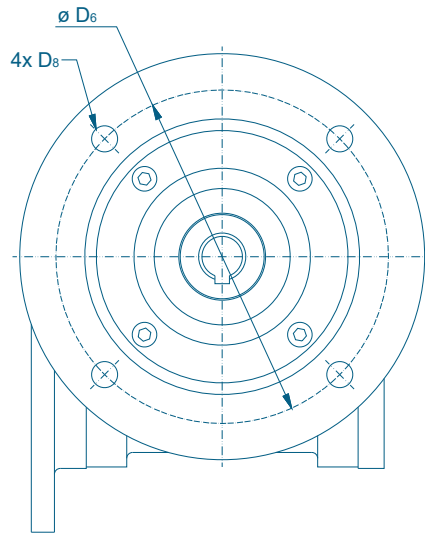
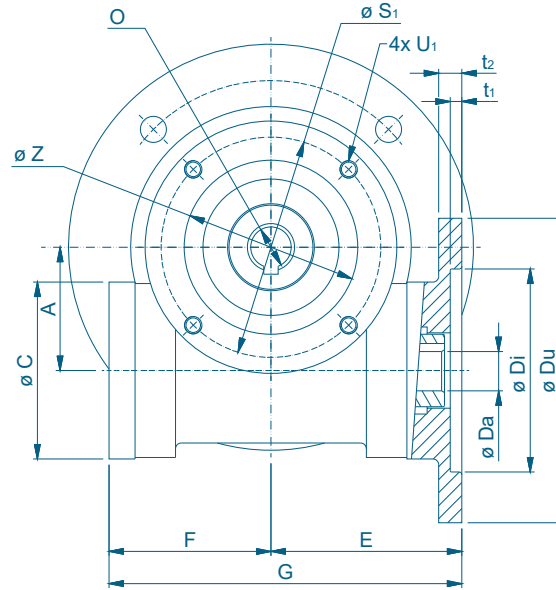
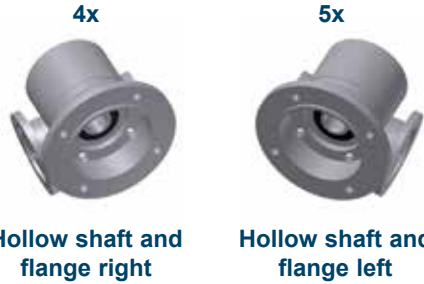

Gearbox - Mounting holes right / left	A	C	D _s	D _e	D _r h _s	D _s	F	L ₂	L ₃	N/2	O*H _s	S ₁	Z h _s	U ₁	Motor size	Flange size	Da*G _r	Dc	Di F _s	Du	D _s	E	G	t ₁	t ₂	Kg
1 42 11410 1101 01															63	75	11	75	60	90	7	66	122	4	8	5,9
1 42 11410 1202 01	42,5	61	140	115	95	9	56	75	32	43	20	76	60	M6	71	85	14	85	70	105	7	66	122	4	8	5,9
1 42 11410 1302 01															80	100	141)	100	80	120	7	66	122	4	8	5,9
1 52 11420 1202 01															71	85	14	85	70	105	7	82	150	4	11	9
1 52 11420 1303 01															80	100	19	100	80	120	7	82	150	4	11	9
1 52 11420 1404 01	52,5	72	140	115	95	9	68	80	32	48	24	95	65	M6	90	115	24	115	95	140	9	92	160	4	11	9
1 52 11420 1504 01															100	130	241)	130	110	160	9	82	160	4	11	9
1 61 11440 1202 01															71	85	14	85	70	105	7	91	173	4	11	12
1 61 11440 1303 01	61	72	200	165	130	11	82	85	36	49	30	108	90	M8	80	100	19	100	80	120	7	91	173	4	11	12
1 61 11440 1404 01															90	115	24	115	95	140	9	101	183	4	11	12
1 61 11440 1504 01															100/112	130	241)	130	110	160	9	91	173	4	11	12
1 79 11450 1303 01															80	100	19	100	80	120	7	118	215	4	11	23
1 79 11450 1404 01	79	82	200	165	130	11	97	100	45	55	35	125	105	M10	90	115	24	115	95	140	9	118	215	4	11	23
1 79 11450 1505 01															100/112	130	28	130	110	160	9	126	225	4	11	23
1 99 11460 1404 01															90	115	24	115	95	140	9	150	277	4	9	47
1 99 11460 1505 01	99	115	250	215	180	15	126,8	115	42	73	48	165	120	M12	100/112	130	28	130	110	160	9	150	277	4	12	47

Key and keyway according to DIN 6885. | *Special dimensions optional. See also page 11 for hollow shaft sizes. | ¹⁾ Not IEC-standard.

Dimensional drawings

1 XX 2010X 1X0X 01

Gear housing type 2. Housing with support, worm at top, free shaft, right / left, closed end cover.

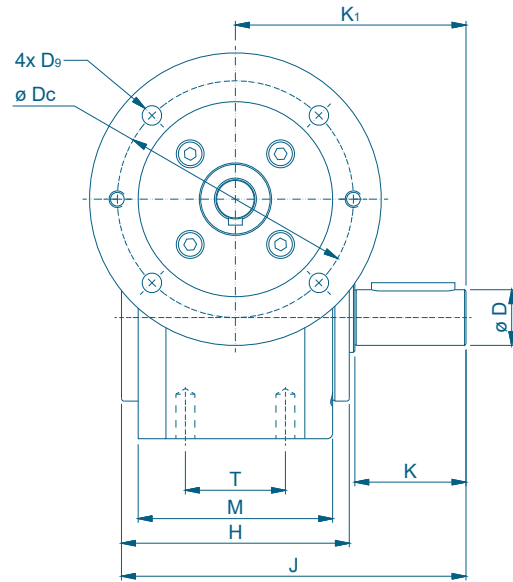
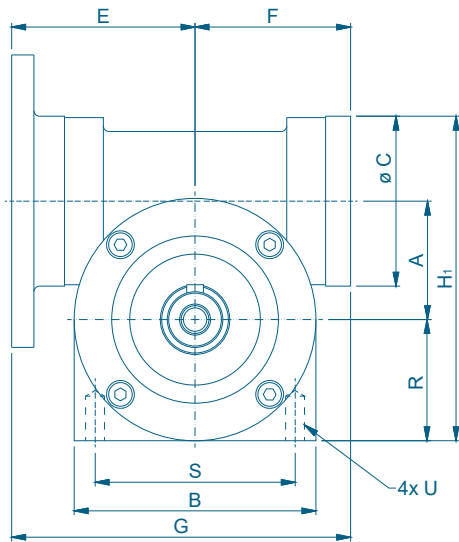
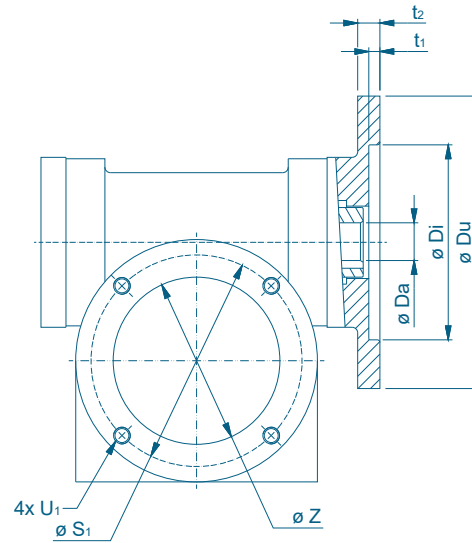

Gearbox - Free shaft right / left	A	B	C	D* ^k	F	H	H ₁	J	K*	K ₁	M	R	S	S ₁	T	Z h _e	U ₁	U	Motor size	Flange size	Da*G ₇	Dc	Di F _s	Du	D _s	E	G	t ₁	t ₂	k Kg
1 42 20100 1101 01																			63	75	11	75	60	90	7	66	122	4	8	4,6
1 42 20100 1202 01	42,5	87	61	20	56	82	116,5	124	40	83	70	43,5	72	76	36	60	M6	M8	71	85	14	85	70	105	7	66	122	4	8	4,6
1 42 20100 1302 01																			80	100	141)	100	80	120	7	66	122	4	8	4,6
1 52 20100 1202 01																			71	85	14	85	70	105	7	82	150	4	11	9
1 52 20100 1303 01																			80	100	19	100	80	120	7	82	150	4	11	9
1 52 20100 1404 01	52,5	110	72	24	68	92	143,5	144	50	98	80	55	85	95	40	65	M6	M10	90	115	24	115	95	140	9	92	160	4	11	9
1 52 20100 1504 01																			100	130	241)	130	110	160	9	82	160	4	11	9
1 61 20100 1202 01																			71	85	14	85	70	105	7	91	173	4	11	11
1 61 20100 1303 01	61	126	72	32	82	94	160	156	60	109	83	63	106	108	42	90	M8	M10	80	100	19	100	80	120	7	91	173	4	11	11
1 61 20100 1404 01																			90	115	24	115	95	140	9	101	183	4	11	11
1 61 20100 1504 01																			100/112	130	241)	130	110	160	9	91	173	4	11	11
1 79 20100 1303 01																			80	100	19	100	80	120	7	118	215	4	11	20
1 79 20100 1404 01	79	164	82	38	97	106	202	173	65	120	92	82	135	125	48	105	M10	M12	90	115	24	115	95	140	9	118	215	4	11	20
1 79 20100 1505 01																			100/112	130	28	130	110	160	9	126	225	4	11	20
1 99 20100 1404 01	99	208	115	48	126,8	142	260,5	234	90	163	120	104	170	165	60	120	M12	M12	90	115	24	115	95	140	9	150	277	4	9	42
1 99 20100 1505 01																			100/112	130	28	130	110	160	9	150	277	4	12	42

Key and keyway according to DIN 6885 | *Special dimensions optional. | ¹⁾ Not IEC-standard.

Dimensional drawings

1 XX 2030X 1X0X 01

Gear housing type 2.

Housing with support, worm at top, double free shaft, closed end cover.



Double free shaft

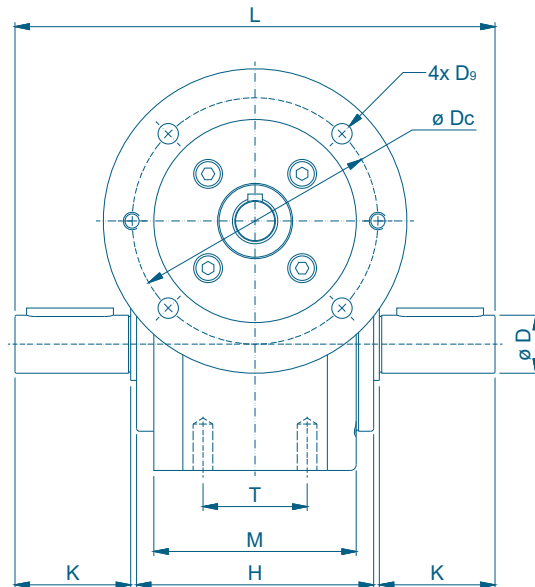
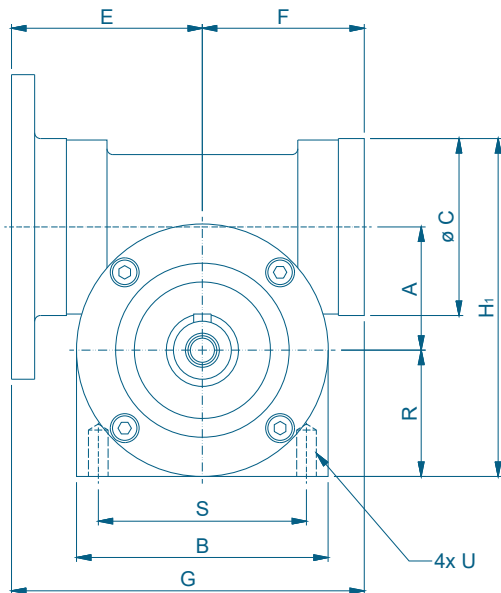
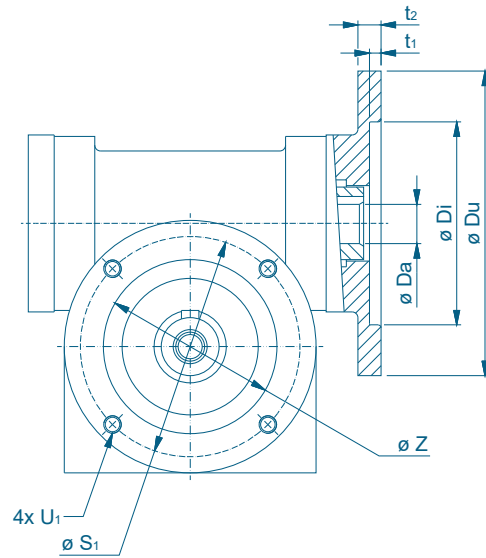

Gearbox - Double free shaft	A	B	C	D* ^k	F	H	H ₁	K*	L	M	R	S	S ₁	T	Z h ₈	U1	U	Motor size	Flange size	Da*G ₇	Dc	Di F ₆	Du	D _ø	E	G	t ₁	t ₂	k Kg
1 42 20300 1101 01																		63	75	11	75	60	90	7	66	122	4	8	4,6
1 42 20300 1202 01	42,5	87	61	20	56	82	116,5	40	166	70	43,5	72	76	36	60	M6	M8	71	85	14	85	70	105	7	66	122	4	8	4,6
1 42 20300 1302 01																		80	100	141)	100	80	120	7	66	122	4	8	4,6
1 52 20300 1202 01																		71	85	14	85	70	105	7	82	150	4	11	9
1 52 20300 1303 01																		80	100	19	100	80	120	7	82	150	4	11	9
1 52 20300 1404 01	52,5	110	72	24	68	92	143,5	50	196	80	55	85	95	40	65	M6	M10	90	115	4	115	95	140	9	92	160	4	11	9
1 52 20300 1504 01																		100	130	241)	130	110	160	9	82	160	4	11	9
1 61 20300 1202 01																		71	85	14	85	70	105	7	91	173	4	11	11
1 61 20300 1303 01																		80	100	19	100	80	120	7	91	173	4	11	11
1 61 20300 1404 01	61	126	72	32	82	94	160	60	218	83	63	106	108	42	90	M8	M10	90	115	24	115	95	140	9	101	183	4	11	11
1 61 20300 1504 01																		100/112	130	241)	130	110	160	9	91	173	4	11	11
1 79 20300 1303 01																		80	100	19	100	80	120	7	118	215	4	11	20
1 79 20300 1404 01	79	164	82	38	97	106	202	65	240	92	82	135	125	48	105	M10	M12	90	115	24	115	95	140	9	118	215	4	11	20
1 79 20300 1505 01																		100/112	130	28	130	110	160	9	126	225	4	11	20
1 99 20300 1404 01																		90	115	24	115	95	140	9	150	277	4	9	42
1 99 20300 1505 01	99	208	115	48	126,8	142	206,5	90	326	120	104	170	165	60	120	M12	M12	100/112	130	28	130	110	160	9	150	277	4	12	42

Key and keyway according to DIN 6885. | *Special dimensions optional. See also page 11 for hollow shaft sizes. | ¹⁾ Not IEC-standard.

Dimensional drawings

1 XX 204XX 1X0X 01

Gear housing type 2 Housing with support, worm at top, hollow shaft, right / left, closed end cover.



4x

Hollow shaft and mounting threads right



5x

Hollow shaft and mounting threads left

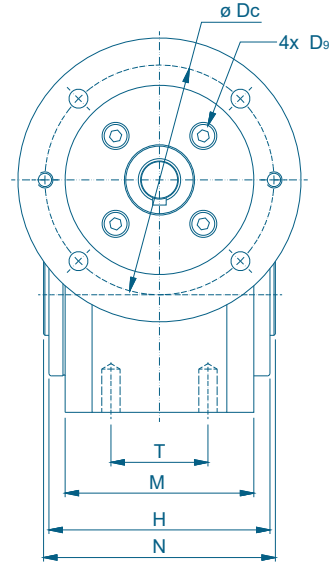
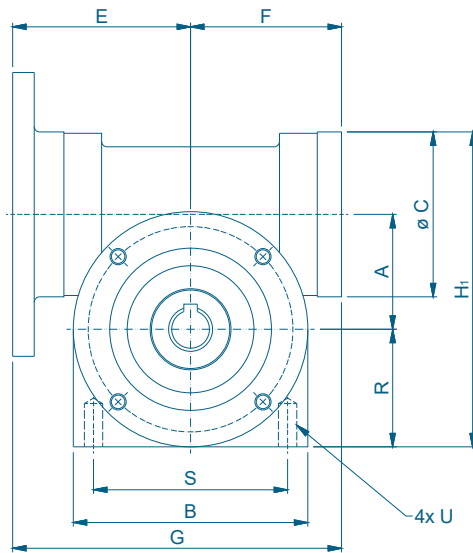
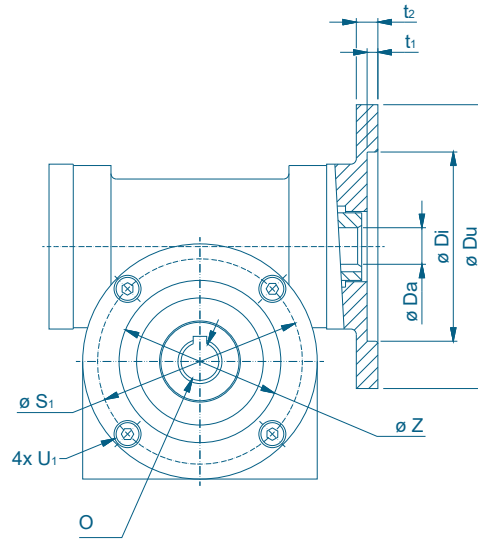

Gearbox - Mounting holes left / right	A	B	C	F	H	H _t	M	N	O*H _s	R	S	S ₁	T	Z	h _s	U ₁	U	Motor size	Flange size	Da*G ₇	Dc	Di	F _s	Du	D _s	E	G	t ₁	t ₂	k	Kg	k	Kg
1 42 20410 1101 01																		63	75	11	75	60	90	7	66	122	4	8	4,6	4,6			
1 42 20410 1202 01	42,5	87	61	56	82	116,5	70	86	20	43,5	72	76	36	60		M6	M8	71	85	14	85	70	105	7	66	122	4	8	4,6	4,6			
1 42 20410 1302 01																		80	100	141)	100	80	120	7	66	122	4	8	4,6	4,6			
1 52 20420 1202 01																		71	85	14	85	70	105	7	82	150	4	11	9	9			
1 52 20420 1303 01																		80	100	19	100	80	120	7	82	150	4	11	9	9			
1 52 20420 1404 01	52,5	110	72	68	92	143,5	80	96	24	55	85	95	40	65		M6	M10	90	115	24	115	95	140	9	92	160	4	11	9	9			
1 52 20420 1504 01																		100	130	241)	130	110	160	9	82	160	4	11	9	9			
1 61 20440 1202 01																		71	85	14	85	70	105	7	91	173	4	11	11	11			
1 61 20440 1303 01																		80	100	19	100	80	120	7	91	173	4	11	11	11			
1 61 20440 1404 01	61	126	72	82	94	160	83	98	30	63	106	108	42	90		M8	M10	90	115	24	115	95	140	9	101	183	4	11	11	11			
1 61 20440 1504 01																		100/112	130	241)	130	110	160	9	91	173	4	11	11	11			
1 79 20450 1303 01																		80	100	19	100	80	120	7	118	215	4	11	20	20			
1 79 20450 1404 01	79	164	82	97	106	202	92	110	35	82	135	125	48	105		M10	M12	90	115	24	115	95	140	9	118	215	4	11	20	20			
1 79 20450 1505 01																		100/112	130	28	130	110	160	9	126	225	4	11	20	20			
1 99 20460 1404 01	99	208	115	126,8	142	260,5	120	146	48	104	170	165	60	120		M12	M12	90	115	24	115	95	140	9	150	277	4	9	42	42			
1 99 20460 1505 01																		100/112	130	28	130	110	160	9	150	277	4	12	42	42			

Key and keyway according to DIN 6885. | *Special dimensions optional. See also page 11 for hollow shaft sizes. | ¹ Not IEC-standard.

Dimensional drawings

1 XX 301XX 1X0X 01

Gear housing type 3. Housing with support, worm at bottom, with free shaft right / left, closed end cover.

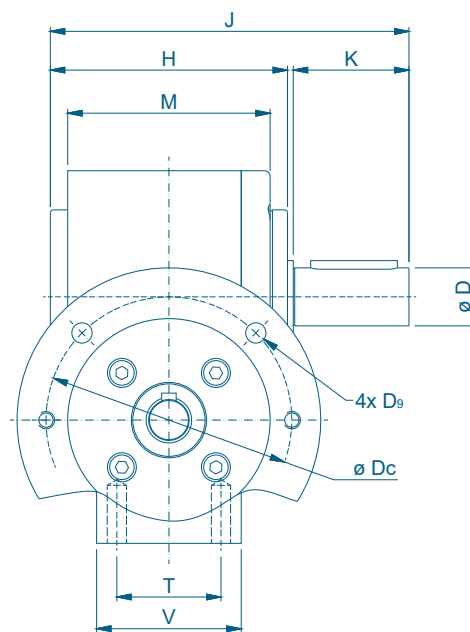
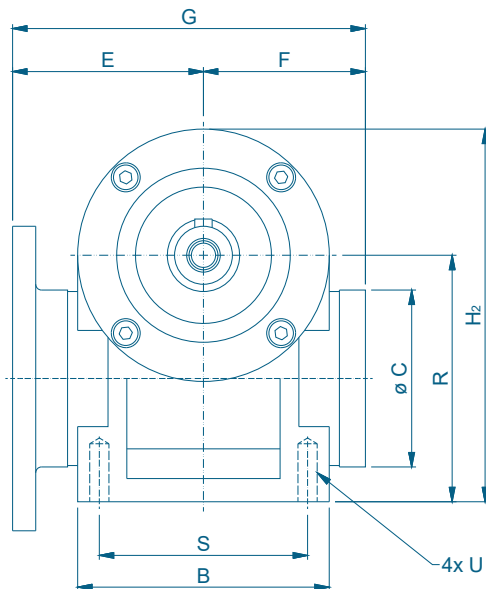
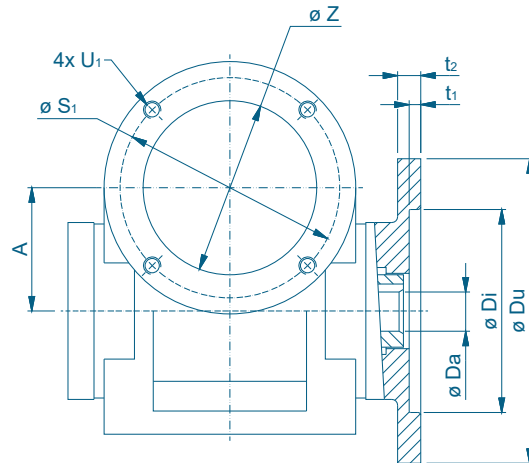

Gearbox - Free shaft right / left	A	B	C	D*ke	F	H	H ₂	J	K*	M	R	S	S ₁	T	V	Z h _e	U ₁	U	Motor size	Flange size	Da*G _r	Dc	Di F _e	Du	D _s	E	G	t ₁	t ₂	kg
1 42 30100 1101 01																			63	75	11	75	60	90	7	66	122	4	8	4,8
1 42 30100 1202 01	42,5	87	61	20	56	82	128,5	124	40	70	85	72	76	36	50	60	M6	M8	71	85	14	85	70	105	7	66	122	4	8	4,8
1 42 30100 1302 01																			80	100	141)	100	80	120	7	66	122	4	8	4,8
1 52 30100 1202 01																			71	85	14	85	70	105	7	82	150	4	11	9
1 52 30100 1303 01																			80	100	19	100	80	120	7	82	150	4	11	9
1 52 30100 1404 01	52,5	110	72	24	68	92	157,5	144	50	80	102,5	85	95	40	60	65	M6	M10	90	115	24	115	95	140	9	92	160	4	11	9
1 52 30100 1504 01																			100	130	241)	130	110	160	9	82	160	4	11	9
1 61 30100 1202 01																			71	85	14	85	70	105	7	91	173	4	11	11
1 61 30100 1303 01																			80	100	19	100	80	120	7	91	173	4	11	11
1 61 30100 1404 01	61	126	72	32	82	94	174	156	60	83	111	106	108	42	72	90	M8	M10	90	115	24	115	95	140	9	101	183	4	11	11
1 61 30100 150401																			100/112	130	241)	130	110	160	9	91	173	4	11	11
1 79 30100 1303 01																			80	100	19	100	80	120	7	118	215	4	11	20
1 79 30100 1404 01	79	164	82	38	97	106	216	173	65	92	134	135	125	48	82	105	M10	M12	90	115	24	115	95	140	9	118	215	4	11	20
1 79 30100 1505 01																			100/112	130	28	130	110	160	9	126	225	4	11	20
1 99 30100 1404 01	99	208	115	48	126,8	142	273	234	90	120	170	170	165	60	96	120	M12	M12	90	115	24	115	95	140	9	150	277	4	9	42
1 99 30100 1505 01																			100/112	130	28	130	110	160	9	150	277	4	12	42

Key and keyway according to DIN 6885 | *Special dimensions optional. See also page 11 for hollow shaft sizes. | ¹⁾Not IEC-standard.

Dimensional drawings

1 XX 303XX 1X0X 01

Gear housing type 3. Housing with support, worm at bottom, double free shaft, closed end cover.



Double free shaft

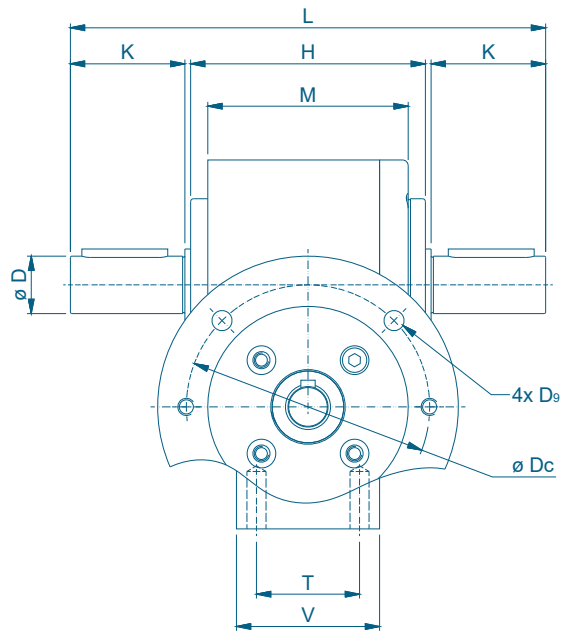
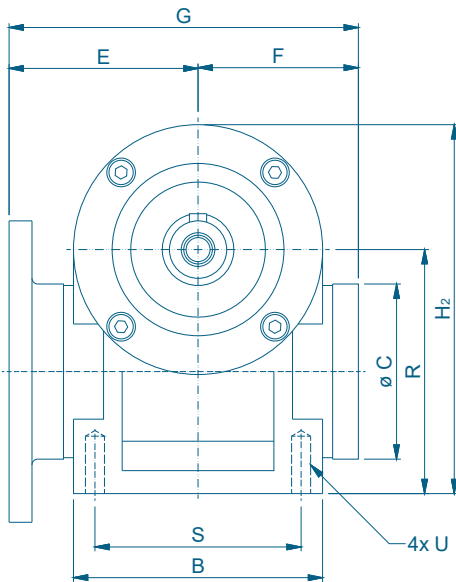
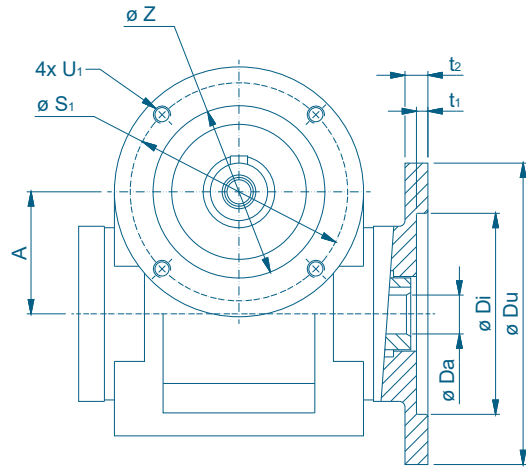

Gearbox - Double free shaft	A	B	C	D*k _e	F	H	H ₂	K*	L	M	R	S	S ₁	T	V	Z h _e	U ₁	U	Motor size	Flange size	Da*G ₇	Dc	Di F _e	Du	D ₉	E	G	t ₁	t ₂	kg	k Kg
1 42 30300 1101 01																			63	75	11	75	60	90	7	66	122	4	8	4,8	4,6
1 42 30300 1202 01	42,5	87	61	20	56	82	128,5	40	166	70	85	72	76	36	50	60	M6	M8	71	85	14	85	70	105	7	66	122	4	8	4,8	4,6
1 42 30300 1302 01																			80	100	141)	100	80	120	7	66	122	4	8	4,8	4,6
1 52 30300 1202 01																			71	85	14	85	70	105	7	82	150	4	11	9	9
1 52 30300 1303 01																			80	100	19	100	80	120	7	82	150	4	11	9	9
1 52 30300 1404 01	52,5	110	72	24	68	92	157,5	50	196	80	102,5	85	95	40	60	65	M6	M10	90	115	24	115	95	140	9	92	160	4	11	9	9
1 52 30300 1504 01																			100	130	241)	130	110	160	9	82	160	4	11	9	9
1 61 30300 1202 01																			71	85	14	85	70	105	7	91	173	4	11	11	11
1 61 30300 1303 01																			80	100	19	100	80	120	7	91	173	4	11	11	11
1 61 30300 1404 01	61	126	72	32	82	94	174	60	218	83	111	106	108	42	72	90	M8	M10	90	115	24	115	95	140	9	101	183	4	11	11	11
1 61 30300 1504 01																			100/112	130	241)	130	110	160	9	91	173	4	11	11	11
1 79 30300 1303 01																			80	100	19	100	80	120	7	118	215	4	11	20	20
1 79 30300 1404 01	79	164	82	38	97	106	216	65	240	92	134	135	125	48	82	105	M10	M12	90	115	24	115	95	140	9	118	215	4	11	20	20
1 79 30300 1505 01																			100/112	130	28	130	110	160	9	126	225	4	11	20	20
1 99 30300 1404 01																			90	115	24	115	95	140	9	150	277	4	9	42	42
1 99 30300 1505 01	99	208	115	48	126,8	142	273	90	326	120	170	170	165	60	96	120	M12	M12	100/112	130	28	130	110	160	9	150	277	4	12	42	42

Key and keyway according to DIN 6885 | *Special dimensions optional. See also page 11 for hollow shaft sizes. | ¹⁾ Not IEC-standard.

Dimensional drawings

1 XX 304XX 1X0X 01

Gear housing type 3. Housing with support, worm at bottom, hollow shaft, mounting holes right / left, closed end cover.



4x
Hollow shaft and mounting threads right



5x
Hollow shaft and mounting threads left

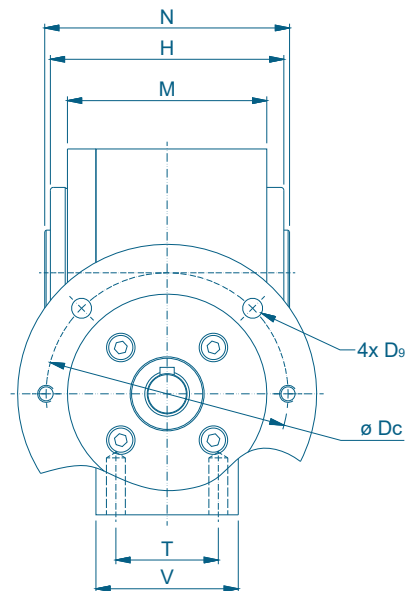
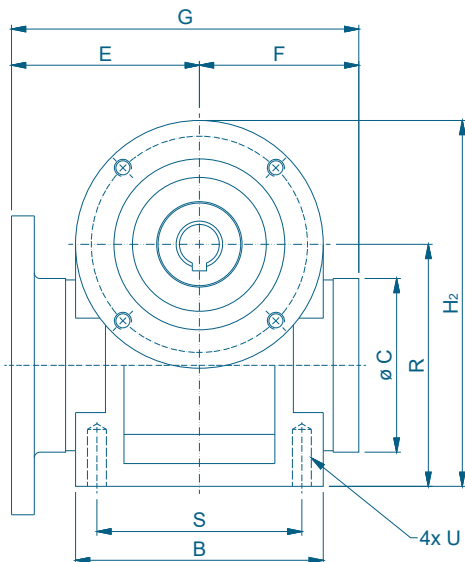
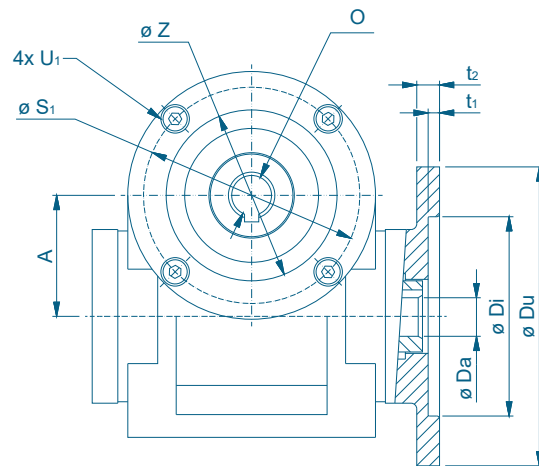

Gearbox - Mounting Holes Right / Left	A	B	C	F	H	H ₂	M	N	O*H ₆	R	S	S ₁	T	V	Z h ₆	U ₁	U	Motor size	Flange size	Da*G ₇	Dc	Di F ₆	Du	D ₉	E	G	t ₁	t ₂	kg
1 42 30410 1101 01																		63	75	11	75	60	90	7	66	122	4	8	4,8
1 42 30410 1202 01	42,5	87	61	56	82	128,5	70	86	20	85	72	76	36	50	60	M6	M8	71	85	14	85	70	105	7	66	122	4	8	4,8
1 42 30410 1302 01																		80	100	141)	100	80	120	7	66	122	4	8	4,8
1 52 30420 1202 01																		71	85	14	85	70	105	7	82	150	4	11	9
1 52 30420 1303 01																		80	100	19	100	80	120	7	82	150	4	11	9
1 52 30420 1404 01	52,5	110	72	68	92	157,5	80	96	24	102,5	85	95	40	60	65	M6	M10	90	115	24	115	95	140	9	92	160	4	11	9
1 52 30420 1504 01																		100	130	241)	130	110	160	9	82	160	4	11	9
1 61 30440 1202 01																		71	85	14	85	70	105	7	91	173	4	11	11
1 61 30440 1303 01																		80	100	19	100	80	120	7	91	173	4	11	11
1 61 30440 1404 01	61	126	72	82	94	174	83	98	30	111	106	108	42	72	90	M8	M10	90	115	24	115	95	140	9	101	183	4	11	11
1 61 30440 1504 01																		100/112	130	241)	130	110	160	9	91	173	4	11	11
1 79 30450 1303 01																		80	100	19	100	80	120	7	118	215	4	11	20
1 79 30450 1404 01	79	164	82	97	106	216	92	110	35	134	135	125	48	82	105	M10	M12	90	115	24	115	95	140	9	118	215	4	11	20
1 79 30450 1505 01																		100/112	130	28	130	110	160	9	126	225	4	11	20
1 99 30450 1404 01																		90	115	24	115	95	140	9	150	277	4	9	42
1 99 30450 1505 01	99	208	115	126,8	142	273	120	146	48	170	170	165	60	96	120	M12	M12	100/112	130	28	130	110	160	9	150	277	4	12	42

Key and keyway according to DIN 6885 | *Special dimensions optional. See also page 11 for hollow shaft sizes. | ¹⁾ Not IEC-standard.

Dimensional drawings

Free worm shaft at D-side

1 XX XXXXX 3040 01

Free worm shaft at D-side with ND-side closed.
In this example housing type 1.



ND-side closed



Free shaft on ND-side

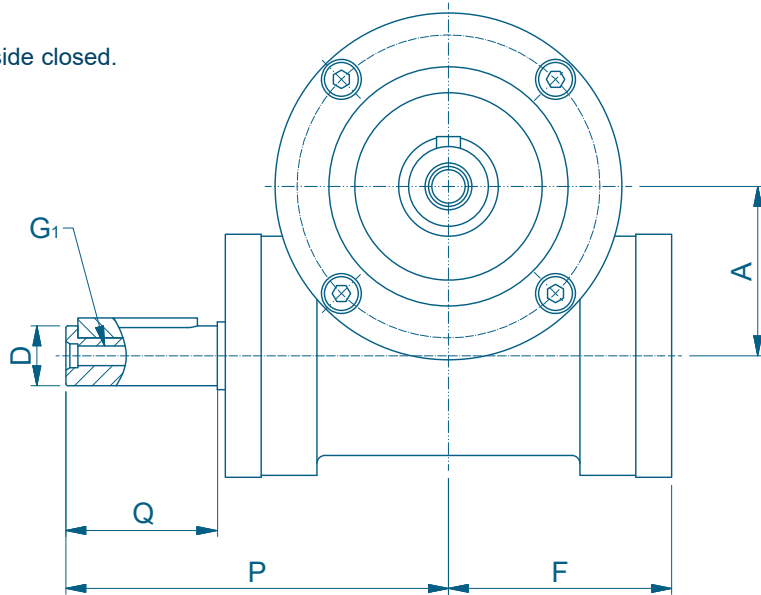

1 XX XXXXX 3050 30

Free worm shaft at D-side with throughgoing worm, and with free shaft on ND-side.
In this example housing type 1 is shown.

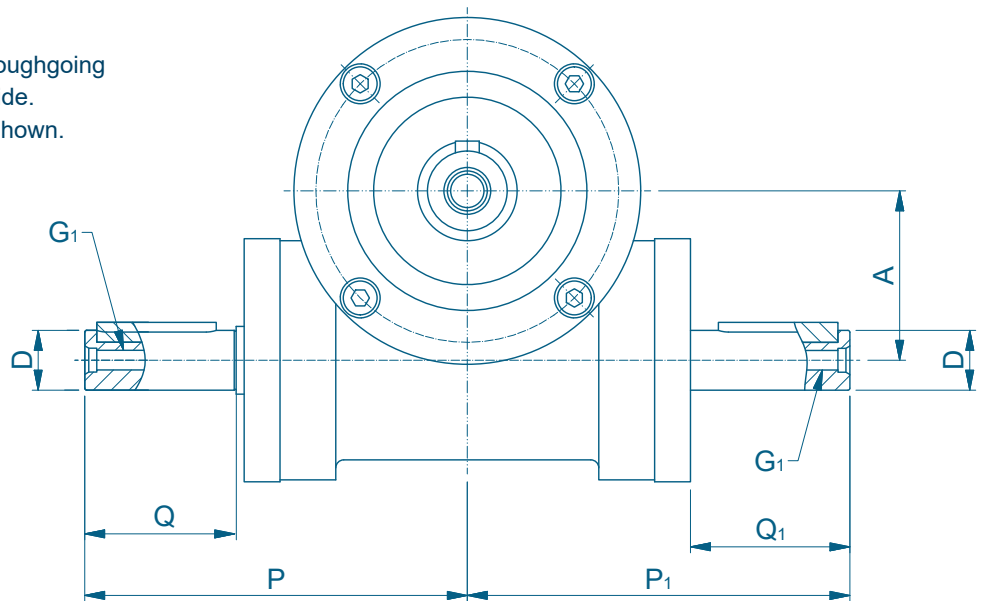

Gearbox	A	D (k6)	F	G ₁	P	P ₁	Q	Q ₁
Series 42	42,5	Ø15	56	M6	96	96	38	40
Series 52	52,5	Ø19	68	M8	110	110	40	42
Series 61	61	Ø19	82	M8	120	123	40	40
Series 79	79	Ø24	97	M8	159	159	60	60
Series 99	99	Ø28	127	M8	189	189	60	60

Key and keyway according to DIN 6885

Dimensional drawings

1 XX XXXXX 1X2X 30

Motor flange and hollow worm at D-side with throughgoing worm, and with free shaft on ND-side.

In this example housing type 1 is shown.



Motor flange free shaft



Coupling housing

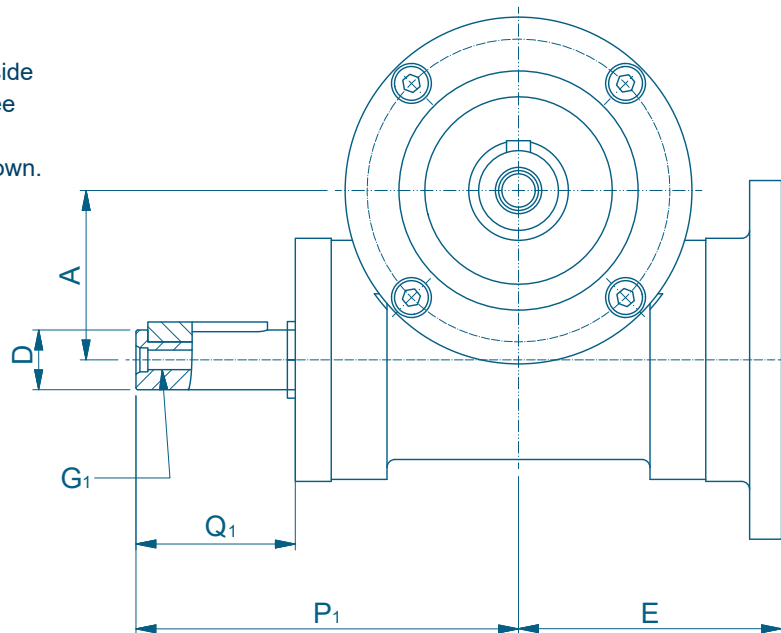

1 XX XXXXX 4X40 01

Coupling housing, free worm shaft at D-side and with ND-side closed.

In this example housing type 1 is shown.

Coupling housing

Motor flange with free worm shaft at D-side

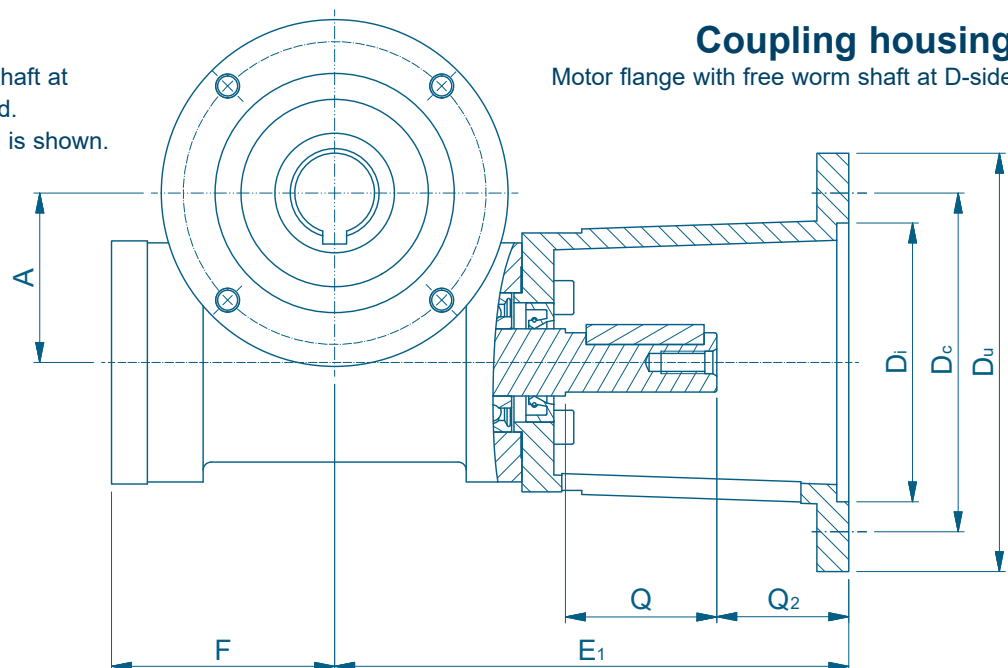

Gearbox	A	D (k6)	Di	Du	Dc	E	E ₁	F	G ₁	P ₁	Q	Q ₁	Q ₂
Series 42	42,5	Ø15	Ø70	Ø105	Ø85	66	129	56	M6	96	38	40	33
Series 52	52,5	Ø19	Ø70	Ø105	Ø85	82	140	68	M8	110	40	42	30
Series 61	61	Ø19	Ø80	Ø120	Ø100	91	175	82	M8	123	40	40	55
Series 79	79	Ø24	Ø95	Ø140	Ø115	118	222,4	97	M8	159	60	60	63,4
Series 99	99	Ø28	Ø110	Ø160	Ø130	150	262	127	M8	189	60	60	73

Key and keyway according to DIN 6885

Mounting instructions

This instruction applies for BJ worm gearboxes size 42, 52, 61, 79 and 99. All according to our catalogues.

Mounting and taking into service shall be done by trained and/or skilled personnel.

Field of application

- Unless otherwise agreed, the gearboxes may be used in ambient temperatures between 0 and +40°C, in normal atmosphere and normal atmospheric pressure.
- If the gearbox is used in a dusty or dirty environment be sure that ingress in glands is avoided. The same goes for outdoor use or wet environments.

Before mounting

- Examine the gearbox for damages and leakages.
- Make sure that the unit corresponds to the unit ordered.
- Some units are deliberately delivered without oil. If so, it is clearly marked. If the unit is delivered without oil, be sure to fill it with the correct type and amount according to this catalogue (see page 14 or at www.bj-gear.com).
- If possible, make a test run of the unit before mounting (see page 33).
- Be sure that unintentional start is not possible.
- If the unit is delivered with motor, electromagnetic brake or coupling, encoder etc., be sure to follow the operating instructions for these.
- Be sure to secure parts that may move inadvertently, thus causing damage or harm. Be aware that not all devices are self-locking.
- Be sure that the mounting planes are stable, clean and plane.

Mounting:

- Use only the holes or threads of the unit that is intended for mounting.
- Do not make changes to the units unless approved by BJ-Gear.
- Do not over-constrain if torque arm is used.
- Be sure to mount it in such a way that sufficient cooling is provided. If the gearbox or motor is provided with cooling fan, be sure that sufficient air flow is accessible.
- Do not use hammering or excessive force during mounting.
- The drive shaft and the driven shaft are to be properly aligned.
- If the gearbox is supplied with a breather valve, the gearbox is to be positioned so it is placed above the oil level. If the gearbox is delivered with a transport screw, the transport screw is to be interchanged with the breather valve. Do not use a motor with higher power than allowed according to catalogue or documentation.
- Do not load the gearbox with higher torque or forces than allowed according to catalogue or documentation.
- Mount the gearbox in such a way that vibrations are minimised or eliminated.
- Secure screws so they cannot loosen.
- Be sure to place parallel keys where needed.

Mounting of motor and other accessories (brake, encoder etc.)

Mounting of motor:

- Lubricate using mounting grease between the motor shaft and the hollow input shaft of the gearbox.
- The input shaft should be pre-greased before mounting.
- Do not use hammering or excessive force during mounting of the motor. It can damage the bearings in the unit.
- If the motor and unit are connected by a coupling, the alignment has to be within the specifications of the coupling.

Mounting of other accessories

- The operating instructions is to be followed at all times.
- Especially with brakes and clutches it is important that there is no dirt, dust, oil or grease on or between friction elements.

Operation and maintenance instructions

Starting up

Before starting up the gearbox, be sure:

- That the motor is properly secured to the unit.
- That the gearbox is properly secured to the application.
- To test the functionality of electric brakes, clutches or safety devices, if installed.
- That brakes and couplings are released.
- That tools, wiring, clothes etc. are removed from moving parts.
- To make the starting as gentle as possible.
- To closely monitor that the intended function occurs and if it does not, shut down the system and search for errors in a safe way.
- To shut down the system and safely check for any unexpected noise or vibration.
- To examine for leakages when the gearbox has reached its operation temperature.

Running-in:

The lifetime of the gearbox will improve if a proper run in is made. A proper run in is as follows:

- The first running time should not exceed half an hour. Run the gearbox for about 15 minutes in each direction with no load.
- Let the gearbox cool down.
- Start it up and load it with an application half the torque. Gradually increase the load to full torque. Do this in both directions.
- It might not always be possible to do as described above, but some running in is better than none.

Oil change

The gearboxes are lifetime lubricated. However, gearboxes subjected to extremely heavy loads must have oil changed approx. every 5 years. Gearboxes operating in very warm environments may require oil changes every year. See page 14 for lubricants and quantities.

Examples from BJ-Gear



Aluminium worm gearbox



Cast iron worm gearbox



Chromatised worm gearbox



Stainless steel gearbox



Series 79 or 99 stainless steel gearbox



Stainless steel worm gearbox with stainless steel motor



Worm gearbox with special output shaft and flange



Worm gearbox with special motorflange, output flange and brake



Worm gearbox with special worm shaft for brake and encoder, as well as a special output flange



Worm gearbox with special motor flange, output shaft and reduced backlash



Worm gearbox with special output shaft and flange



Worm gearbox with special output shaft and flange



High precision worm gearbox dual lead



High precision worm gearbox with special motor flange



Double acting precision gearbox with built-in friction coupling



Worm gearbox with special motorflange, output flange and brake



Stainless worm gearbox with special motor flange for DC motor and stainless motor shield



Highly efficient worm gearbox with DC motor and clutch

Range of BJ-Gear products

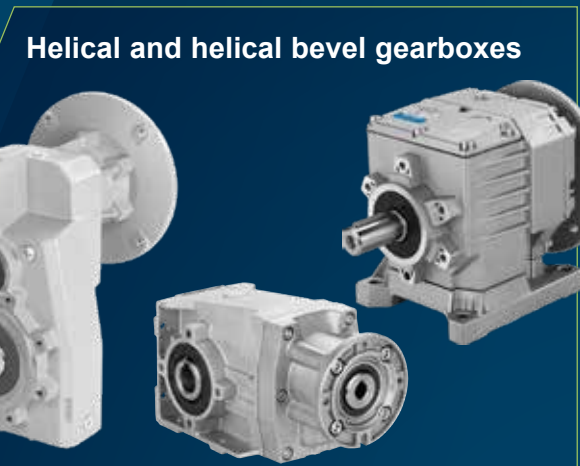

Right angle gearboxes

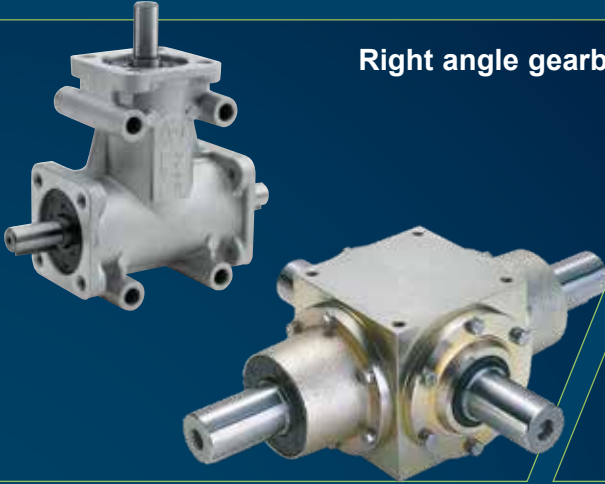

Planetary gearboxes



Adapted products



Special products



Encoders, brakes and clutches



Couplings



Spare parts list

1	Bearing cover
1A	Side flange
2	Gasket
3	Screw
3A	Bolt
3B	Screw
4	Screw
5	Oil seal
6	Oil seal
7	Oil seal
8	Oil seal
8A	Oil seal
9	Ball bearing or tapered roller bearings
10	Ball bearing or tapered roller bearings
11	Ball bearing or tapered roller bearings
12	Ball bearing or tapered roller bearings
13	Worm wheel
14	Worm wheel
15	Spacer ring
16	Spacer ring
17	Hollow output shaft
18	Double output shaft
19	Single output shaft
19A	Single output shaft, extended
20	Hollow worm shaft
20A	Hollow worm with free shaft
21	Free worm shaft
21A	Double free worm shaft
22	Parallel key B
23	Parallel key A
24	Parallel key A
25	Locking ring
26	Washer

27	End cover, open
28	End cover, closed
29	Gasket
30	Motor flange
31	Bearing cover
31A	Side flange
32	Stud cover
33	Screw
35	Gearbox, type 1, for hollow output shaft
36	Gearbox, type 1, for double free output shaft
37	Gearbox, type 1, for free output shaft
38	Gearbox, type 2, with support, worm at top, for hollow output shaft
39	Gearbox, type 2, with support, worm at top, for double free output shaft
40	Gearbox, type 2, with support, worm at top, for free output shaft
41	Gearbox, type 3, with support and worm at bottom, for hollow output shaft
42	Gearbox, type 3, with support and worm at bottom, for double free output shaft
43	Gearbox, type 3, with support and worm at bottom, for free output shaft
44	Locking ring

Spare parts drawing

Hollow output shaft w. side flange

Hollow output shaft

Double output shaft

Free output shaft, common

Extended output shaft and side flange

Double free worm shaft

Motor flange and free worm shaft

Free worm shaft

Motor flange and hollow worm shaft

Housing type 1

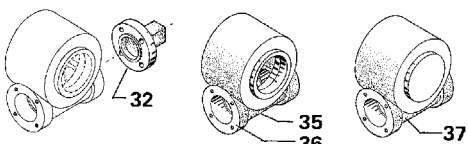

Housing type 2

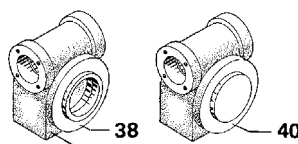

Housing type 3

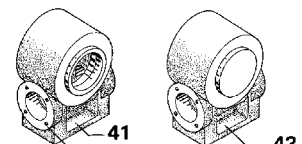

bj·gear

Customisation is our standard



BJ-Gear A/S

Niels Bohrs Vej 47
DK-8660 Skanderborg, Denmark
VAT No. DK 10166470

Phone +45 87 40 80 80
Email bj@bj-gear.com
Website www.bj-gear.com

Copyright © 2022 BJ-Gear A/S. All product rights reserved. All data, illustrations, photos, drawings and statements are for general information only and subject to change without notice and should not be considered as a warranty or legal obligation of any kind.